

TOUGH GUN® CA3 Robotic Air-Cooled MIG Gun

OWNER'S MANUAL

September 2024

OM-CA3-2.4

Robotic, Air-Cooled, Conventional MIG
(GMAW) Welding Gun



bernardtregaskiss.com/TechnicalSupport
1-855-MIGWELD (644-9353)(US & Canada)
+1-519-737-3000(International)

Thank You for Choosing Tregaskiss®

Thank you for selecting a Tregaskiss product. Before installing, compare the equipment received against the invoice to verify that the shipment is complete and undamaged. It is the responsibility of the purchaser to file all claims of damage or loss that may have occurred during transit with the carrier.

The owner's manual contains general information, instructions and maintenance to help better maintain your MIG gun or peripheral. Please read, understand and follow all safety precautions.

While every precaution has been taken to assure the accuracy of this owner's manual, Tregaskiss assumes no responsibility for errors or omissions. Tregaskiss assumes no liability for damages resulting from the use of information contained herein. The information presented in this owner's manual is accurate to the best of our knowledge at the time of printing. Please reference bernardtregaskiss.com for updated material.

For customer support and special applications, please call the Tregaskiss Customer Service Department at 1-855-MIGWELD (644-9353) (US & Canada) or +1-519-737-3000 (International), fax 1-519-737-1530, or email at cs@itwmig.com. Our trained Customer Service Team is available between 8:00 a.m. and 5:30 p.m. EST, and will answer your product application or repair questions.

Tregaskiss manufactures premium robotic MIG (GMAW) welding guns, peripherals and consumables. For more information on other premium Tregaskiss products, contact your local Tregaskiss distributor or visit us on the web at bernardtregaskiss.com.

Subject to Change – The information presented in this manual is accurate to the best of our knowledge at the time of printing. Please visit bernardtregaskiss.com for the most up-to-date information.

Additional Material – For additional support materials such as spec sheets, troubleshooting information, how-to guides and videos, animations, online configurators and much more, please visit bernardtregaskiss.com.

Scan this QR Code with your smart phone for immediate access to bernardtregaskiss.com/TechnicalSupport



TABLE OF CONTENTS

DECLARATION OF CONFORMITY	V
DECLARATION OF CONFORMITY	VI
SECTION 1 — SAFETY PRECAUTIONS — READ BEFORE USING	1
1-1 Symbol Usage	1
1-2 Arc Welding Hazards	1
1-3 California Proposition 65 Warnings	3
1-4 Principal Safety Standards	3
1-5 EMF Information	3
SECTION 2 — CONSIGNES DE SÉCURITÉ — LIRE AVANT UTILISATION	4
2-1 Symboles utilisés	4
2-2 Dangers relatifs au soudage à l'arc	4
2-3 Proposition californienne 65 avertissements	6
2-4 Principales normes de sécurité	6
2-5 Informations relatives aux CEM	6
SECTION 3 — PRECAUCIONES DE SEGURIDAD — LEA ANTES DE USAR	7
3-1 Uso de símbolos	7
3-2 Peligros en soldadura de arco	7
3-3 Advertencias de la Proposición 65 del estado de California	9
3-4 Estándares principales de seguridad	9
3-5 Información sobre los campos electromagnéticos (EMF)	9
SECTION 4 — PRODUCT WARRANTY	10
4-1 Product Warranty	10
SECTION 5 — SPECIFICATIONS	11
5-1 System Components	11
SECTION 6 — INSTALLATION	12
6-1 Installing Gun to Robot	12
6-2 Installing Gun to Wire Feeder	14
6-3 Installing Clutch Cable to Gun	15
6-4 Connecting Wire Brake and/or Air Blast	15
SECTION 7 — REPLACEMENT	16
7-1 Changing Consumables	16
7-2 Changing the Neck	17
7-3 Changing TOUGH GUN I.C.E.™ Components	17

7-4 Changing the Liner	19
7-5 Changing the Power Pin or AutoLength™ Pin	20
7-6 Changing the Replaceable Unicable	21
7-7 Replacing the Wire Brake	22
SECTION 8 — TECHNICAL DATA	24
8-1 Wiring Diagram	24
8-2 Center of Mass Coordinates	25
SECTION 9 — PARTS LIST	26
SECTION 10 — TROUBLESHOOTING	27
10-1 Troubleshooting Table	27
ADDITIONAL SUPPORT MATERIALS	29

DECLARATION OF CONFORMITY

for European Community (CE marked) products



Tregaskiss, 2570 North Talbot Rd., Oldcastle, Ontario NOR 1L0 Canada declares that the product(s) identified in this declaration conform to the essential requirements and provisions of the stated Council Directive(s) and Standard(s).

Product/Apparatus Identification:

Product	Stock Number
Tregaskiss TOUGH GUN CA3 Series	RA1XXXXXXXXX (Configurable #)

Council Directives:

- 2014/35/EU Low voltage
- 2011/65/EU and amendment 2015/863 Restriction of the use of certain hazardous substances in electrical and electronic equipment

Electronic equipment standards:

- EN IEC 60974-7:2019 Arc welding equipment – Part 7: Torches
- EN IEC 63000:2018 Technical documentation for the assessment of electrical and electronic products with respect to the restriction of hazardous substances

Signatory:

March 22, 2017

David A. Werba
MANAGER, PRODUCT DESIGN COMPLIANCE

Date of Declaration

DECLARATION OF CONFORMITY

for United Kingdom (UKCA marked) products



Tregaskiss, 2570 North Talbot Rd., Oldcastle, Ontario NOR 1L0 Canada declares that the product(s) identified in this declaration conform to the essential requirements and provisions of the stated Council Directive(s) and Standard(s).

Product/Apparatus Identification:

Product	Stock Number
Tregaskiss TOUGH GUN CA3 Series	RA1XXXXXXXX (Configurable #)

Council Directives:

- S.I. 2016/1101 Electrical Equipment (Safety) Regulations 2016
- S.I. 2012/3032 Restriction of the Use of Certain Hazardous Substances in Electrical and Electronic Equipment Regulations

Standards:

- EN IEC 60974-7:2019 Arc welding equipment – Part 7: Torches
- EN IEC 63000:2018 Technical documentation for the assessment of electrical and electronic products with respect to the restriction of hazardous substances

Signatory:

March 22, 2017

David A. Werba
MANAGER, PRODUCT DESIGN COMPLIANCE

Date of Declaration

SECTION 1 — SAFETY PRECAUTIONS — READ BEFORE USING



Protect yourself and others from injury – read, follow, and save these important safety precautions and operating instructions.

1-1 Symbol Usage



DANGER! – Indicates a hazardous situation which, if not avoided, will result in death or serious injury. The possible hazards are shown in the adjoining symbols or explained in the text.



Indicates a hazardous situation which, if not avoided, could result in death or serious injury. The possible hazards are shown in the adjoining symbols or explained in the text.

NOTICE – Indicates statements not related to personal injury.

 – Indicates special instructions.



This group of symbols means Warning! Watch Out! ELECTRIC SHOCK, MOVING PARTS, and HOT PARTS hazards. Consult symbols and related instructions below for necessary actions to avoid the hazards.

1-2 Arc Welding Hazards



The symbols shown below are used throughout this manual to call attention to and identify possible hazards. When you see the symbol, watch out, and follow the related instructions to avoid the hazard. The safety information given below is only a summary of the more complete safety information found in section 1-4 Principal Safety Standards on page 3, and in welding power source Owner's Manual. Read and follow all Safety Standards.



Only qualified persons should install, operate, maintain, and repair this equipment. A qualified person is defined as one who, by possession of a recognized degree, certificate, or professional standing, or who by extensive knowledge, training and experience, has successfully demonstrated ability to solve or resolve problems relating to the subject matter, the work, or the project and has received safety training to recognize and avoid the hazards involved.



During operation, keep everybody, especially children, away.

ELECTRIC SHOCK can kill.

- Always wear dry insulating gloves.
- Insulate yourself from work and ground.
- Do not touch live electrode or electrical parts.



- Replace worn, damaged, or cracked guns or cables.
- Turn off welding power source before changing contact tip or gun parts.
- Keep all covers and handle securely in place.

FUMES AND GASES can be hazardous.

- Keep your head out of the fumes.
- Ventilate area, or use breathing device. The recommended way to determine adequate ventilation is to sample for the composition and quantity of fumes and gases to which personnel are exposed.
- Read and understand the Safety Data Sheets (SDSs) and the manufacturer's instructions for adhesives, coatings, cleaners, consumables, coolants, degreasers, fluxes, and metals.



MOVING PARTS can injure.

- Keep away from moving parts.
- Keep away from pinch points such as drive rolls.



WELDING can cause fire or explosion.

- Do not weld near flammable material.
- Do not weld on containers that have held combustibles, or on closed containers such as tanks, drums, or pipes unless they are properly prepared according to AWS F4.1 and AWS A6.0 (see Safety Standards).
- Watch for fire; keep extinguisher nearby.
- Read and understand the Safety Data Sheets (SDSs) and the manufacturer's instructions for adhesives, coatings, cleaners, consumables, coolants, degreasers, fluxes, and metals.



BUILDUP OF GAS can injure or kill.

- Shut off compressed gas supply when not in use.
- Always ventilate confined spaces or use approved air-supplied respirator.



ARC RAYS can burn eyes and skin.

Arc rays from the welding process produce intense visible and invisible (ultraviolet and infrared) rays that can burn eyes and skin. Sparks fly off from the weld.



- Wear an approved welding helmet fitted with a proper shade of filter lenses to protect your face and eyes from arc rays and sparks when welding or watching (see ANSI Z49.1 and Z87.1 listed in Safety Standards).
- Wear approved safety glasses with side shields under your helmet.
- Use protective screens or barriers to protect others from flash, glare and sparks; warn others not to watch the arc.
- Wear body protection made from leather or flame-resistant clothing (FRC). Body protection includes oil-free clothing such as leather gloves, heavy shirt, cuffless trousers, high shoes, and a cap.

HOT PARTS can burn.

- Allow gun to cool before touching.
- Do not touch hot metal.
- Protect hot metal from contact by others.



NOISE can damage hearing.

Noise from some processes or equipment can damage hearing.



- Check for noise level limits exceeding those specified by OSHA.
- Use approved ear plugs or ear muffs if noise level is high.
- Warn others nearby about noise hazard.

WELDING WIRE can injure.

- Keep hands and body away from gun tip when trigger is pressed.



READ INSTRUCTIONS.

- Read and follow all labels and the Owner's Manual carefully before installing, operating, or servicing unit. Read the safety information at the beginning of the Manual and in each section.
- Use only genuine replacement parts from the manufacturer.
- Perform installation, maintenance, and service according to the Owner's Manuals, industry standards, and national, state, and local codes.

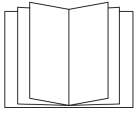

1-3 California Proposition 65 Warnings



WARNING: This product can expose you to chemicals including lead, which are known to the state of California to cause cancer and birth defects or other reproductive harm.

For more information, go to www.P65Warnings.ca.gov.

1-4 Principal Safety Standards

Safety in Welding, Cutting, and Allied Processes, American Welding Society standard ANSI Standard Z49.1. Website: www.aws.org.

Safe Practice For Occupational And Educational Eye And Face Protection, ANSI Standard Z87.1, from American National Standards Institute. Website: www.ansi.org.

Safe Practices for the Preparation of Containers and Piping for Welding and Cutting, American Welding Society Standard AWS F4.1. Website: www.aws.org.

National Electrical Code, NFPA Standard 70 from National Fire Protection Association. Website: www.nfpa.org.

Safe Handling of Compressed Gases in Cylinders, CGA Pamphlet P-1 from Compressed Gas Association. Website: www.cganet.com.

Safety in Welding, Cutting, and Allied Processes, CSA Standard W117.2 from Canadian Standards Association. Website: www.csagroup.org.

Standard for Fire Prevention During Welding, Cutting, and Other Hot Work, NFPA Standard 51B from National Fire Protection Association. Website: www.nfpa.org.

OSHA, Occupational Safety and Health Standards for General Industry, Title 29, Code of Federal Regulations (CFR), Part 1910.177 Subpart N, Part 1910 Subpart Q, and Part 1926, Subpart J. Website: www.osha.gov.

SR7 2022-01

1-5 EMF Information

Electric current flowing through any conductor causes localized electric and magnetic fields (EMF). The current from arc welding (and allied processes including spot welding, gouging, plasma arc cutting, and induction heating operations) creates an EMF field around the welding circuit. EMF fields may interfere with some medical implants, e.g. Pacemakers. Protective measures for persons wearing medical implants have to be taken. For example, restrict access for passersby or conduct individual risk assessment for welders. All welders should use the following procedures in order to minimize exposure to EMF fields from the welding circuit:

1. Keep cables close together by twisting or taping them, or using a cable cover.
2. Do not place your body between welding cables. Arrange cables to one side and away from the operator.

3. Do not coil or drape cables around your body.
4. Keep head and trunk as far away from the equipment in the welding circuit as possible.
5. Connect work clamp to workpiece as close to the weld as possible.
6. Do not work next to, sit or lean on the welding power source.
7. Do not weld whilst carrying the welding power source wire feeder.

About Implanted Medical Devices:

Implanted Medical Device wearers should consult their doctor and the device manufacturer before performing or going near arc welding, spot welding, gouging, plasma arc cutting, or induction heating operations. If cleared by your doctor, then following the above procedures is recommended.

SECTION 2 — CONSIGNES DE SÉCURITÉ — LIRE AVANT UTILISATION

 Pour écarter les risques de blessure pour vous-même et pour autrui — lire, appliquer et ranger en lieu sûr ces consignes relatives aux précautions de sécurité et au mode opératoire.

2-1 Symboles utilisés

 **DANGER!** – Indique une situation dangereuse qui si on l'évite pas peut donner la mort ou des blessures graves. Les dangers possibles sont montrés par les symboles joints ou sont expliqués dans le texte.

 Indique une situation dangereuse qui si on l'évite pas peut donner la mort ou des blessures graves. Les dangers possibles sont montrés par les symboles joints ou sont expliqués dans le texte.

AVIS – Indique des déclarations pas en relation avec des blessures personnelles.

 – Indique des instructions spécifiques.



Ce groupe de symboles veut dire Avertissement! Attention! DANGER DE CHOC ELECTRIQUE, PIECES EN MOUVEMENT, et PIECES CHAUDES. Reportez-vous aux symboles et aux directives cidessous afin de connaître les mesures à prendre pour éviter tout danger.

2-2 Dangers relatifs au soudage à l'arc

 Les symboles donnés ci-après sont utilisés dans tout le manuel pour attirer l'attention sur les dangers possibles et pour indiquer le type de danger dont il s'agit. Quand on voit le symbole, prendre garde et suivre les directives correspondantes pour éviter le danger. Les consignes de sécurité présentées ci-après ne font que résumer l'information contenue dans les Normes de sécurité principales, et dans le Guide d'utilisation de la source de courant de soudage. Lire et suivre toutes les Normes de sécurité.

 L'installation, l'utilisation, l'entretien et les réparations ne doivent être confiés qu'à des personnes qualifiées. Une personne qualifiée est définie comme celle qui, par la possession d'un diplôme reconnu, d'un certificat ou d'un statut professionnel, ou qui, par une connaissance, une formation et une expérience approfondies, a démontré avec succès sa capacité à résoudre les problèmes liés à la tâche, le travail ou le projet et a reçu une formation en sécurité afin de reconnaître et d'éviter les risques inhérents.

 Au cours de l'utilisation, tenir toute personne à l'écart et plus particulièrement les enfants.

UN CHOC ÉLECTRIQUE peut tuer.



- Porter toujours des gants secs et isolants.
- S'isoler de la pièce et de la terre.
- Ne jamais toucher une électrode ou des pièces électriques sous tension.
- Remplacer les pistolets ou câbles de soudage qui sont endommagés, usés ou craquelés.
- Mettre la soudeuse hors tension avant de remplacer un bec contact ou des pièces de pistolet.
- S'assurer que tous les couvercles et poignées sont fermement assujettis.

LES FUMÉES ET LES GAZ peuvent être dangereux.



- Garder la tête hors des fumées.
- Aérer la zone de travail ou porter un appareil respiratoire. Pour déterminer la bonne ventilation, il est recommandé de procéder à un prélèvement pour la composition et la quantité de fumées et de gaz auxquels est exposé le personnel.
- Lire et comprendre les fiches de données de sécurité et les instructions du fabricant concernant les adhésifs, les revêtements, les nettoyants, les consommables, les produits de refroidissement, les dégraisseurs, les flux et les métaux.

Les PIÈCES MOBILES peuvent causer des blessures.



- Ne pas s'approcher des organes mobiles.
- Ne pas s'approcher des points de coincement tels que des rouleaux de commande.

Le SOUDAGE peut provoquer un incendie ou une explosion.



- Ne pas souder à proximité de matériaux inflammables
- Ne pas effectuer le soudage sur des conteneurs fermés tels que des réservoirs, tambours, ou conduites, à moins qu'ils n'aient été préparés correctement conformément à AWS F4.1 et AWS A6.0 (voir les Normes de Sécurité).
- Prendre garde aux incendies et toujours avoir un extincteur à proximité.

- Lire et comprendre les fiches de données de sécurité et les instructions du fabricant concernant les adhésifs, les revêtements, les nettoyants, les consommables, les produits de refroidissement, les dégraissateurs, les flux et les métaux.

L'ACCUMULATION DE GAZ risquent de provoquer des blessures ou même la mort.



- Fermer l'alimentation du gaz comprimé en cas de non utilisation.
- Veiller toujours à bien aérer les espaces confinés ou se servir d'un respirateur d'adduction d'air homologué.

LE RAYONNEMENT DE L'ARC peut brûler les yeux et la peau.



Le rayonnement de l'arc du procédé de soudage génère des rayons visibles et invisibles intenses (ultraviolets et infrarouges) susceptibles de provoquer des brûlures dans les yeux et sur la peau. Des étincelles sont projetées pendant le soudage.

- Porter un casque de soudage approuvé muni de verres filtrants approprié pour protéger visage et yeux pendant le soudage (voir ANSI Z49.1 et Z87.1 énuméré dans les normes de sécurité).
- Porter des lunettes de sécurité avec écrans latéraux même sous votre casque.
- Avoir recours à des écrans protecteurs ou à des rideaux pour protéger les autres contre les rayonnements les éblouissements et les étincelles ; prévenir toute personne sur les lieux de ne pas regarder l'arc.
- Porter une protection corporelle en cuir ou des vêtements ignifuges (FRC). La protection du corps comporte des vêtements sans huile, comme des gants de cuir, une chemise solide, des pantalons sans revers, des chaussures hautes et une casquette.

LES PIÈCES CHAUDES peuvent provoquer des brûlures.



- Laisser refroidir le pistolet avant de le toucher.
- Ne pas toucher d'objets métalliques chauds.
- Abrisser les objets métalliques contre tout contact par les personnes à proximité.

Le BRUIT peut endommager l'ouïe.

Le bruit des processus et des équipements peut affecter l'ouïe.



- Vérifier si les niveaux de bruit excèdent les limites spécifiées par l'OSHA.
- Utiliser des bouches-oreilles ou des serre-tête antibruit approuvés si le niveau de bruit est élevé.

- Avertir les personnes à proximité au sujet du danger inhérent au bruit.

LES FILS DE SOUDAGE peuvent provoquer des blessures.



- Éloigner les mains et le corps de la buse du pistolet après avoir appuyé sur la gâchette.

LIRE LES INSTRUCTIONS.

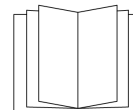

- Lire et appliquer les instructions sur les étiquettes et le Mode d'emploi avant l'installation, l'utilisation ou l'entretien de l'appareil. Lire les informations de sécurité au début du manuel et dans chaque section.
- N'utiliser que les pièces de remplacement provenant du fabricant.
- Effectuer l'installation, l'entretien et toute intervention selon les manuels d'utilisateurs, les normes nationales, provinciales et de l'industrie, ainsi que les codes municipaux.

2-3 Proposition californienne 65 avertissements



AVERTISSEMENT – Ce produit peut vous exposer à des produits chimiques tels que le plomb, reconnus par l'État de Californie comme cancérigènes et sources de malformations ou d'autres troubles de la reproduction

Pour plus d'informations, consulter www.P65Warnings.ca.gov.

2-4 Principales normes de sécurité

Safety in Welding, Cutting, and Allied Processes, American Welding Society standard ANSI Standard Z49.1. Website: www.aws.org.

Safe Practice For Occupational And Educational Eye And Face Protection, ANSI Standard Z87.1, from American National Standards Institute. Website: www.ansi.org.

Safe Practices for the Preparation of Containers and Piping for Welding and Cutting, American Welding Society Standard AWS F4.1 from Global Engineering Documents. Website: www.aws.org.

National Electrical Code, NFPA Standard 70 from National Fire Protection Association. Website: www.nfpa.org.

Safe Handling of Compressed Gases in Cylinders, CGA Pamphlet P-1 from Compressed Gas Association. Website: www.cganet.com.

Safety in Welding, Cutting, and Allied Processes, CSA Standard W117.2 from Canadian Standards Association. Website: www.csagroup.org.

Standard for Fire Prevention During Welding, Cutting, and Other Hot Work, NFPA Standard 51B from National Fire Protection Association. Website: www.nfpa.org.

OSHA, Occupational Safety and Health Standards for General Industry, Title 29, Code of Federal Regulations (CFR), Part 1910.177 Subpart N, Part 1910 Subpart Q, and Part 1926, Subpart J. Website: www.osha.gov.

SR7_fre 2022-01

2-5 Informations relatives aux CEM

Le courant électrique qui traverse tout conducteur génère des champs électromagnétiques (CEM) à certains endroits. Le courant issu d'un soudage à l'arc (et de procédés connexes, y compris le soudage par points, le gougeage, le découpage plasma et les opérations de chauffage par induction) crée un champ électromagnétique (CEM) autour du circuit de soudage. Les champs électromagnétiques produits peuvent causer interférence à certains implants médicaux, p. ex. les stimulateurs cardiaques. Des mesures de protection pour les porteurs d'implants médicaux doivent être prises: par exemple, des restrictions d'accès pour les passants ou une évaluation individuelle des risques pour les soudeurs. Tous les soudeurs doivent appliquer les procédures suivantes pour minimiser l'exposition aux CEM provenant du circuit de soudage:

1. Rassembler les câbles en les torsadant ou en les attachant avec du ruban adhésif ou avec une housse.
2. Ne pas se tenir au milieu des câbles de soudage. Disposer les câbles d'un côté et à distance de l'opérateur.

3. Ne pas courber et ne pas entourer les câbles autour de votre corps.
4. Maintenir la tête et le torse aussi loin que possible du matériel du circuit de soudage.
5. Connecter la pince sur la pièce aussi près que possible de la soudure.
6. Ne pas travailler à proximité d'une source de soudage, ni s'asseoir ou se pencher dessus.
7. Ne pas souder tout en portant la source de soudage ou le dévidoir.

En ce qui concerne les implants médicaux :

Les porteurs d'implants doivent d'abord consulter leur médecin avant de s'approcher des opérations de soudage à l'arc, de soudage par points, de gougeage, du coupage plasma ou de chauffage par induction. Si le médecin approuve, il est recommandé de suivre les procédures précédentes.

SECTION 3 — PRECAUCIONES DE SEGURIDAD — LEA ANTES DE USAR

 Protéjase usted mismo y a otros contra lesiones — lea, cumpla y conserve estas importantes precauciones de seguridad e instrucciones de utilización.

3-1 Uso de símbolos

 **PELIGRO!** — Indica una situación peligrosa que, si no se la evita, resultará en muerte o lesión grave. Los peligros posibles se muestran en los símbolos adjuntos o se explican en el texto.

 Indica una situación peligrosa que, si no se la evita, podría resultar en muerte o lesión grave. Los peligros posibles se muestran en los símbolos adjuntos, o se explican en el texto.

AVISO — Indica precauciones no relacionadas a lesiones personales.

 — Indica instrucciones especiales.



Este grupo de símbolos significa ¡Advertencia!, ¡Cuidado! CHOQUE O DESCARGA ELÉCTRICA, PIEZAS QUE SE MUEVEN, y peligros de PARTES CALIENTES. Consulte los símbolos y las instrucciones relacionadas que aparecen a continuación para ver las acciones necesarias para evitar estos peligros.

3-2 Peligros en soldadura de arco

 Los símbolos mostrados abajo se usan en todo este manual para llamar la atención a e identificar los posibles peligros. Cuando vea el símbolo, preste atención y siga las instrucciones relacionadas para evitar el peligro. La información de seguridad dada abajo es solamente un resumen de la información más completa de seguridad que se encuentra en los estándares de seguridad, y la fuente de alimentación para soldadura del Manual del usuario. Lea y siga todas las normas de seguridad.

 Solamente personal cualificado debe instalar, utilizar, mantener y reparar este equipo. La definición de personal cualificado es cualquier persona que, debido a que posee un título, un certificado o una posición profesional reconocida, o gracias a su gran conocimiento, capacitación y experiencia, haya demostrado con éxito la capacidad para solucionar o resolver problemas relacionados con el trabajo, el proyecto o el tema en cuestión, además de haber asistido a una capacitación en seguridad para reconocer y evitar los peligros que implica el proceso.

 Durante su operación mantenga lejos a todos, especialmente a los niños.

UNA DESCARGA ELÉCTRICA puede matarlo.



- Siempre use guantes aislantes secos.
- Aíslese usted mismo del trabajo y la tierra.
- No toque electrodo eléctricamente vivo o partes eléctricamente vivas.
- Reemplace antorchas o cables desgastados, dañados o rotos.
- Repare o reemplace aislamiento de la pistola o del cable que esté desgastado, dañado o agrietado.
- Apague la máquina de soldar antes de cambiar los tubos de contacto o piezas de la antorcha.
- Mantenga todas las tapas y asa bien seguras en sitio.

HUMO y GASES pueden ser peligrosos.



- Mantenga su cabeza fuera del humo.
- Ventile el lugar o use un aparato para respirar. El método recomendado para determinar la ventilación adecuada es tomar muestras de la composición y cantidad de humos y gases a los que está expuesto el personal.
- Lea y entienda las Hojas de datos del material (SDS) y las instrucciones del fabricante relacionadas con los adhesivos, metales, consumibles, recubrimientos, limpiadores, refrigerantes, desengrasadores, fundentes y metales.

Las PIEZAS MÓVILES pueden provocar lesiones.



- Aléjese de toda parte en movimiento.
- Aléjese de todo punto que pellizque, tal como rodillos impulsados.

EL SOLDAR puede causar fuego o explosión.



- No suelde cerca de material inflamable
- No suelde en recipientes que han contenido combustibles, ni en recipientes cerrados como tanques, tambores o tuberías, a menos que estén preparados correctamente de acuerdo con la norma AWS F4.1 y AWS A6.0 (vea las normas de seguridad).
- Siempre mire que no haya fuego y mantenga un extinguidor de fuego cerca.
- Lea y entienda las Hojas de datos del material (SDS) y las instrucciones del fabricante relacionadas con los adhesivos, metales, consumibles, recubrimientos, limpiadores, refrigerantes, desengrasadores, fundentes y metales.

EL AMONTONAMIENTO DE GAS puede enfermarle o matarle.



- Cierre el suministro de gas comprimido cuando no lo use.
- Siempre dé ventilación a espacios cerrados o use un respirador aprobado que reemplaza el aire.

LOS RAYOS DEL ARCO pueden quemar sus ojos y piel.



Los rayos del arco de un proceso de suelda producen un calor intenso y rayos ultravioletas fuertes que pueden quemar los ojos y la piel. Las chispas se escapan de la soldadura.

- Use una careta para soldar aprobada equipada con un filtro de protección apropiado para proteger su cara y ojos de los rayos del arco y de las chispas mientras esté soldando o mirando. (véase los estándares de seguridad ANSI Z49.1 y Z87.1).
- Use anteojos de seguridad aprobados que tengan protección lateral.
- Use pantallas de protección o barreras para proteger a otros del destello, reflejos y chispas, alerte a otros que no miren el arco.
- Use protección para el cuerpo hecha de cuero o de prendas resistentes a las llamas (FRC). Entre la protección para el cuerpo se incluye la ropa sin aceite, como guantes de cuero, una camisa gruesa, pantalones sin vuelta, calzado alto y una gorra.

PARTES CALIENTES pueden causar quemaduras severas.



- Permita que la antorcha se enfríe antes de tocarla.
- No toque metal caliente.
- Proteja a otros del contacto con el metal caliente.

EL RUIDO puede trastornar su oído.



Ruido proveniente de algunos procesos o equipo puede dañar el oído.

- Chequee los límites del nivel del ruido si exceden aquellos especificados por OSHA.
- Use tapas para los oídos o cubiertas para los oídos si el nivel del ruido es demasiado alto.
- Advierta a otros que estén cerca acerca del peligro del ruido.

El ALAMBRE de SOLDAR puede causarle heridas.



- Mantenga las manos y el cuerpo lejos del tubo de contacto de la antorcha cuando se haya presionado el gatillo.

LEER INSTRUCCIONES.

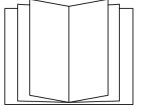

- Lea y siga cuidadosamente las instrucciones contenidas en todas las etiquetas y en el Manual del usuario antes de instalar, utilizar o realizar tareas de mantenimiento en la unidad. Lea la información de seguridad incluida en la primera parte del manual y en cada sección.
- Utilice únicamente piezas de reemplazo legítimas del fabricante.
- Los trabajos de instalación y mantenimiento deben ser ejecutados de acuerdo con las instrucciones del manual del usuario, las normas del sector y los códigos nacionales, estatales y locales.

3-3 Advertencias de la Proposición 65 del estado de California



ADVERTENCIA: Este producto puede exponerlo a químicos, incluso plomo, que el estado de California conoce como causantes de cáncer, defectos de nacimiento u otros daños reproductivos.

Para obtener más información, acceda a www.P65Warnings.ca.gov.

3-4 Estándares principales de seguridad

Safety in Welding, Cutting, and Allied Processes, American Welding Society standard ANSI Standard Z49.1. Website: www.aws.org.

Safe Practice For Occupational And Educational Eye And Face Protection, ANSI Standard Z87.1, from American National Standards Institute. Website: www.ansi.org.

Safe Practices for the Preparation of Containers and Piping for Welding and Cutting, American Welding Society Standard AWS F4.1 from Global Engineering Documents. Website: www.aws.org.

National Electrical Code, NFPA Standard 70 from National Fire Protection Association. Website: www.nfpa.org.

Safe Handling of Compressed Gases in Cylinders, CGA Pamphlet P-1 from Compressed Gas Association. Website: www.cganet.com.

Safety in Welding, Cutting, and Allied Processes, CSA Standard W117.2 from Canadian Standards Association. Website: www.csagroup.org.

Standard for Fire Prevention During Welding, Cutting, and Other Hot Work, NFPA Standard 51B from National Fire Protection Association. Website: www.nfpa.org.

OSHA, Occupational Safety and Health Standards for General Industry, Title 29, Code of Federal Regulations (CFR), Part 1910.177 Subpart N, Part 1910 Subpart Q, and Part 1926, Subpart J. Website: www.osha.gov.

SR7_spa 2022-01

3-5 Información sobre los campos electromagnéticos (EMF)

La corriente que fluye a través de un conductor genera campos eléctricos y magnéticos (EMF) localizados. La corriente del arco de soldadura (y otras técnicas afines como la soldadura por puntos, el ranurado, el corte por plasma y el calentamiento por inducción) genera un campo EMF alrededor del circuito de soldadura. Los campos EMF pueden interferir con algunos dispositivos médicos implantados como, por ejemplo, los marcapasos. Por lo tanto, se deben tomar medidas de protección para las personas que utilizan estos implantes médicos. Por ejemplo, aplique restricciones al acceso de personas que pasan por las cercanías o realice evaluaciones de riesgo individuales para los soldadores. Todos los soldadores deben seguir los procedimientos que se indican a continuación con el objeto de minimizar la exposición a los campos EMF generados por el circuito de soldadura:

1. Mantenga los cables juntos retorciéndolos entre sí o uniéndolos mediante cintas o una cubierta para cables.
2. No ubique su cuerpo entre los cables de soldadura. Disponga los cables a un lado y apartelos del operario.

3. No enrolle ni cuelgue los cables sobre su cuerpo.
4. Mantenga la cabeza y el tronco tan apartados del equipo del circuito de soldadura como le sea posible.
5. Conecte la pinza de masa en la pieza lo más cerca posible de la soldadura.
6. No trabaje cerca de la fuente de alimentación para soldadura, ni se siente o recueste sobre ella.
7. No suelde mientras transporta la fuente de alimentación o el alimentador de alambre.

Acerca de los aparatos médicos implantados:

Las personas que usen aparatos médico implantados deben consultar con su médico y el fabricante del aparato antes de llevar a cabo o acercarse a soldadura de arco, soldadura de punto, ranurar, hacer corte por plasma, u operaciones de calentamiento por inducción. Si su doctor lo permite, entonces siga los procedimientos de arriba.

SECTION 4 — PRODUCT WARRANTY

4-1 Product Warranty

Limited Warranty

Tregaskiss' Products shall, from the date of original purchase (or, solely with respect to Low Stress Robotic Unicables packaged with any Tregaskiss® Robotic MIG Gun, from the date the product goes into production for its intended use) and for the period set forth below, be free from defects in material and workmanship. To obtain repair or replacement of any Product, the covered Product must be delivered, transportation pre-paid by Purchaser, to the address specified by Tregaskiss on its Returned Materials Authorization, with: (i) written proof of warranty coverage (e.g., Purchaser dated purchase order); (ii) serial number on product (if any); (iii) the Product's installed location within Purchaser's facility and usage of the Product; and (iv) written specification of any alleged defect(s). In the event the foregoing materials are not timely provided to Tregaskiss by claimant, warranty coverage will be determined by Tregaskiss, in its sole discretion. For the avoidance of doubt, the warranty period for any Product or part/component of any Product that is replaced or repaired by Tregaskiss under the foregoing warranty is not extended or renewed at the time of such replacement or repair. **The Warranty against defects does not apply to: (1) consumable components or ordinary wear items; (2) products which are improperly altered, modified, stored, installed, operated, handled, used or neglected or use of the Products with equipment, components or parts not specified or supplied by Tregaskiss or contemplated under the Product documentation; or (3) Products which have not been operated, maintained, and repaired pursuant to Product documentation provided by Tregaskiss. Purchaser shall pay Tregaskiss for all warranty claim costs incurred by Tregaskiss (including inspection, labor, parts, testing, scrap and freight) due to warranty claims submitted by Purchaser which are not covered by Tregaskiss' warranty.**

- Bernard® BTB Semi-Automatic Air-Cooled MIG Guns: **1 year**; *Lifetime warranty on straight handles, straight handle switches, and rear strain relief*
- Bernard® W-Gun™ and T-Gun™ Semi-Automatic Water-Cooled MIG Guns: **180 days**
- Bernard® TGX® Chassis and Bernard TGX Ready To Weld MIG Guns: **90 days**
- Tregaskiss® Robotic MIG Guns and Components: **1 year**
- Tregaskiss® Automatic MIG Guns: **1 year**
- Tregaskiss® TOUGH GUN® Reamer:
 - When factory-equipped with lubricator: **2 years** when factory-equipped with lubricator
 - When (i) factory-equipped with lubricator and (ii) used exclusively with Tregaskiss® TOUGH GARD® Anti-Spatter Liquid: **3 years** when both (i) and (ii)
- Tregaskiss® TOUGH GUN® Robotic Peripheral (Clutch, Sprayer, Wire Cutter, Arms): **1 year**
- Tregaskiss® Low-Stress Robotic Unicables (LSR+ Unicables): **6 months**

Service Warranty

Tregaskiss warrants the Services shall conform to any mutually agreed upon specifications or statements of work. Purchaser's sole remedy, and Tregaskiss's sole liability, for a breach of the foregoing warranty is for Tregaskiss, at its option, to re-perform the Services or credit Purchaser's account for such Services.

Limitation of Liability and Remedies

TREGASKISS WILL NOT BE LIABLE, AND PURCHASER WAIVES ALL CLAIMS AGAINST TREGASKISS FOR INDIRECT, INCIDENTAL, SPECIAL, PUNITIVE OR CONSEQUENTIAL DAMAGES, DOWN TIME, LOST PROFITS OR COMMERCIAL LOSSES, WHETHER OR NOT BASED UPON TREGASKISS' NEGLIGENCE OR BREACH OF WARRANTY OR STRICT LIABILITY IN TORT OR ANY OTHER CAUSE OF ACTION. IN NO EVENT WILL TREGASKISS' LIABILITY IN CONNECTION WITH THE AGREEMENT OR SALE OF TREGASKISS' PRODUCTS OR SERVICES EXCEED THE PURCHASE PRICE OF THE SPECIFIC PRODUCTS OR SERVICES AS TO WHICH THE CLAIM IS MADE.

SECTION 5 — SPECIFICATIONS

5-1 System Components

Robotic MIG Gun for GMAW Welding

Duty Cycle Rating: 100%: 385 amps with Mixed Gases

For complete parts list, please see Section 9 — Parts List on page 26.

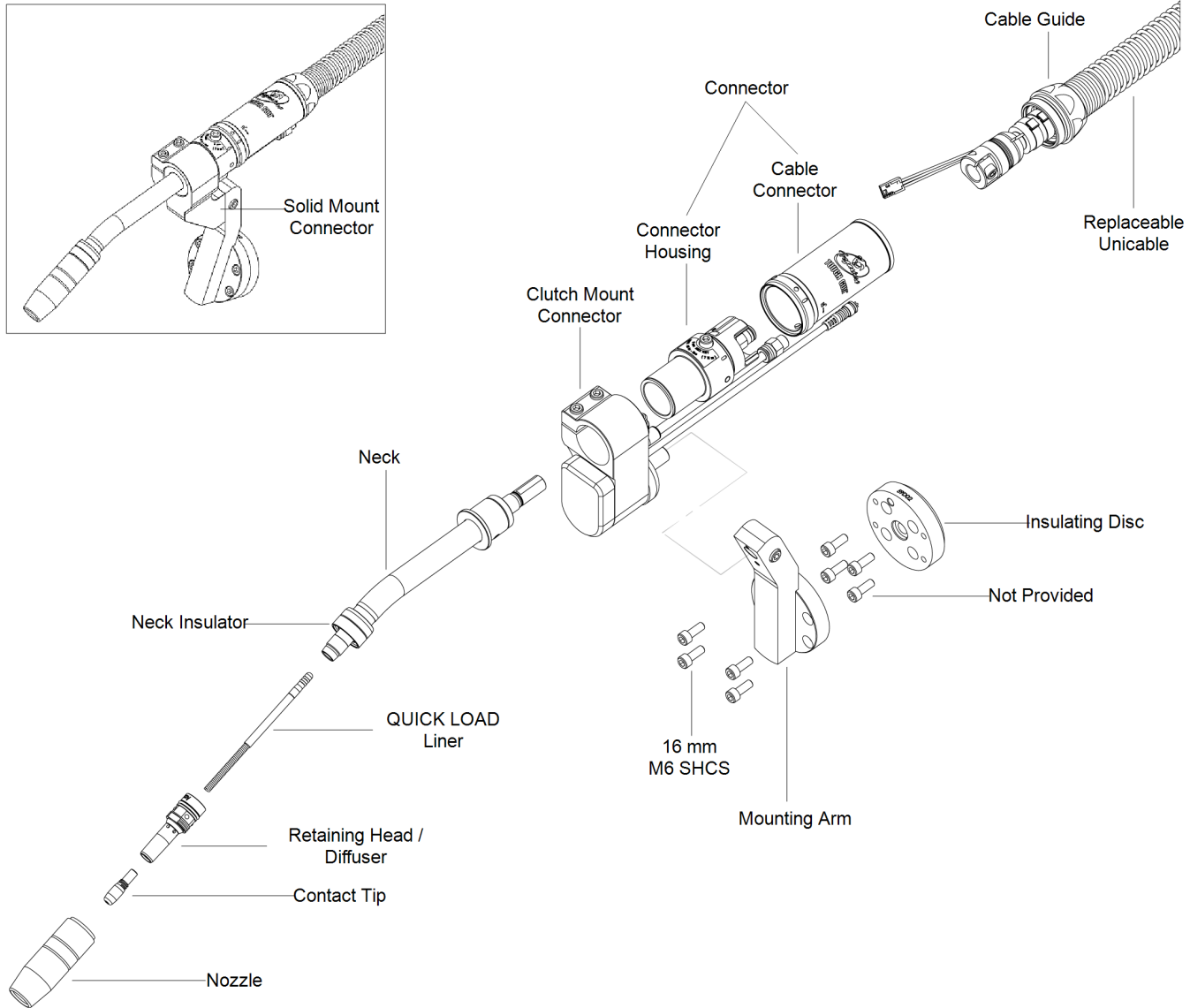

SECTION 6 — INSTALLATION

6-1 Installing Gun to Robot



A. Installing Disc to Robot

1. Bring robot to service position.
2. Align the dowel in the wrist with the dowel hole in the insulating disc and fully seat the disc on the robot wrist.
NOTE: Dowel not provided.
3. Install the disc to the robot with fasteners using the supplied tightening pattern (see Figure 6-A). **IMPORTANT:** Do not use the fasteners to pull the face of the insulating disc to the face of the robot wrist, as damage will occur.
NOTE: Fasteners are not provided since the size varies by robot.
4. Torque to 45 in-lbs (5 Nm).

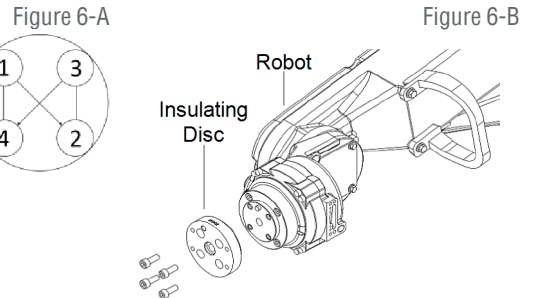
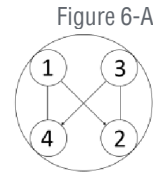

B. Installing Mounting Arm to Disc

1. Align dowel on mounting arm with the dowel hole in insulating disc and seat it by hand.
2. Install the mounting arm to the disc on the robot with 6 mm SHCS (provided) using the supplied tightening pattern (see Figure 6-A). **IMPORTANT:** Do not use fasteners to pull the mounting arm to the face of the insulating disc, as damage will occur.
3. Torque to 45 in-lbs (5 Nm).

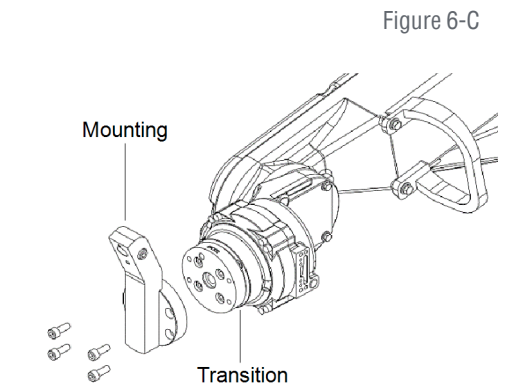

C. Installing Clutch or Solid Mount Clamp to Mounting Arm

1. Remove the fastener and the locking pin from the mounting arm.
2. Insert the clutch / solid mount stud into the mounting arm on the robot until it bottoms out.
3. Once the stud is fully seated in the mounting arm, reinstall the fastener and locking pin. **IMPORTANT:** The flat feature of the locking pin must interface with the flat feature on the clutch or solid mount stud to achieve proper locking and orientation as shown below in Figure 6-G, Figure 6-H and Figure 6-I (solid mount shown).
4. Insert the 6 mm SHCS on the opposite side of the arm and screw it into the locking pin.
5. Torque 6 mm SHCS to 60 in-lbs (7 Nm).

Figure 6-D

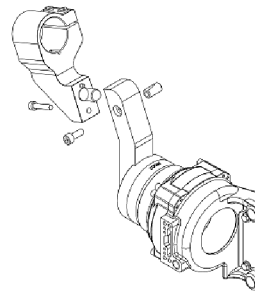

Solid Mount Shown

Figure 6-E

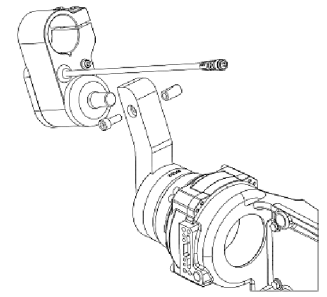

Clutch Mount Shown

Figure 6-F

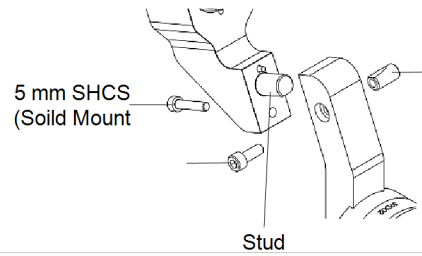

For Solid Mount Models Only:

6. Insert 5 mm SHCS through solid mount clamp assembly and screw into the mounting arm as shown in Figure 6-H.
7. Torque 5 mm SHCS to 45 in-lbs (5 Nm).

Figure 6-G

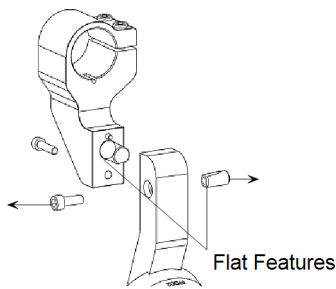

Figure 6-H

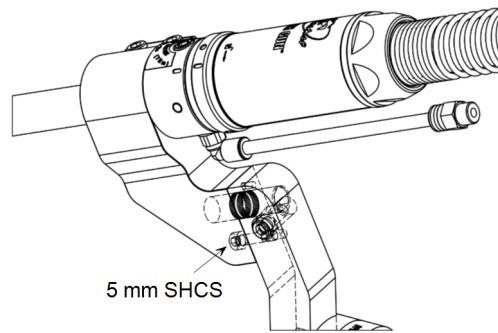
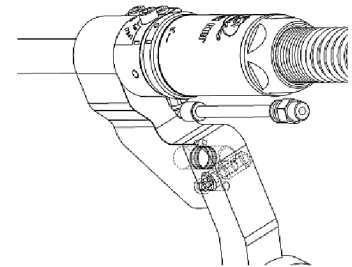

Figure 6-I



D. Installing Gun to Gun Mount

Figure 6-J

1. Loosen clamp screws in mounting clamp.
2. Fully insert gun into the clamp, aligning the key on the gun with the keyway on the clamp.
3. Tighten the 6 mm SHCS using a 5 mm Allen wrench to secure the gun in place.

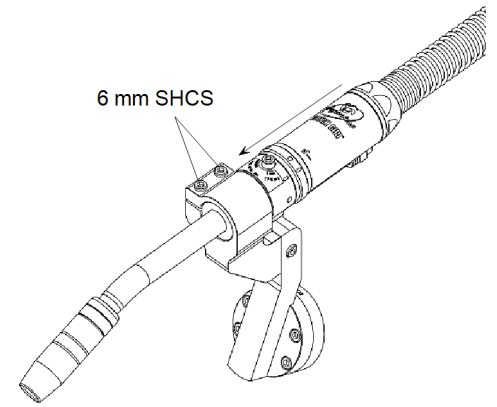

6-2 Installing Gun to Wire Feeder



1. Plug gun into feeder and lock in place (see your feeder manual for details). Connect external gas if required.
 2. **OPTIONAL:** Connect voltage sense lead (see your feeder manual for details) on the replaceable unicable with the male connector on the power jumper cable.
 3. **FOR CLUTCH INSTALLATIONS:** Connect clutch cable with either the provided connections (cut and splice required) or one of our jumper cables (sold separately and available only for select robot models).
- NOTE:** Be sure to align any features to allow for proper installation.

Figure 6-K

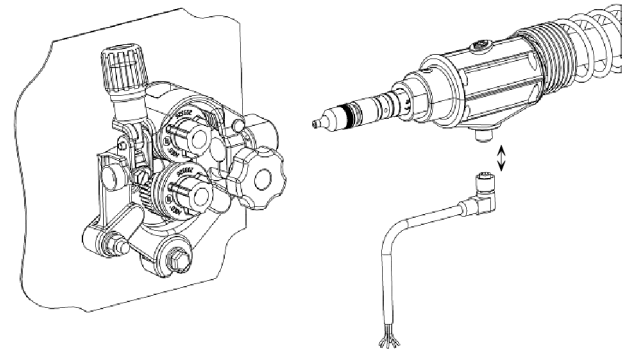

6-3 Installing Clutch Cable to Gun



1. Connect cable supplied with clutch mount to the receptacle on the gun body.
2. Tighten securely by hand.

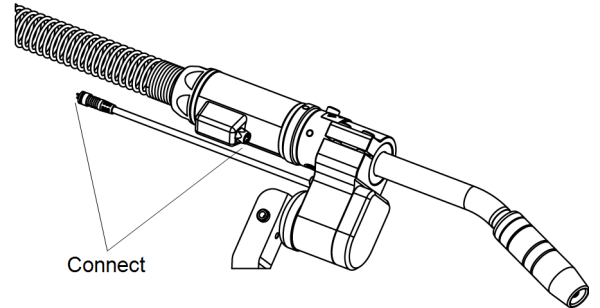
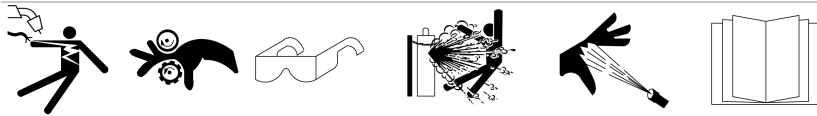

Figure 6-L

6-4 Connecting Wire Brake and/or Air Blast



A. Wire Brake

1. Route wire brake air line to designated control valve in your facility (not provided).
2. 40-60 psi air supply required for proper operation.

B. Air Blast

1. Route air blast air line to designated control valve in your facility (not provided).
2. 80-100 psi air supply required for proper operation.

SECTION 7 — REPLACEMENT

7-1 Changing Consumables

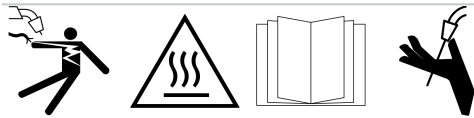
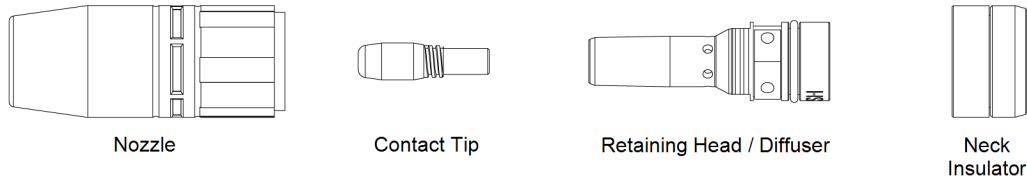

Figure 7-A



IMPORTANT NOTES:

- Neck insulator **MUST** be in place before welding to properly insulate gun.
- Check all parts to ensure that connections are tight before welding.
- The retaining head / diffuser **MUST** be tightened with a 5/8" (16 mm) wrench to prevent the contact tip from overheating.
- **DO NOT** use pliers to remove or tighten the retaining head / diffuser or scoring may result.

A. Changing the Nozzle

1. Pull slip-on nozzles off with a twisting motion.
2. When installing the nozzle, ensure that it is fully seated.

B. Changing the Contact Tip

1. Thread the contact tip into the retaining head / diffuser.
2. Torque to 30 in-lbs (3.5 Nm).
3. The Tregaskiss Tip Tool (part #450-18 for TOUGH LOCK heavy duty tips, or part # T-ALTOOL for AccuLock tips) or a pair of weld pliers are the optimal tools for contact tip installation.

C. Changing the Retaining Head / Diffuser

1. Thread the retaining head / diffuser onto neck with a 5/8" (16 mm) wrench.
2. Torque to 80 in-lbs (9 Nm).
IMPORTANT: DO NOT use pliers to remove or tighten the heavy duty retaining head / diffuser or scoring may result.

D. Changing the Neck Insulator

1. Remove front-end consumables.
2. The neck insulator is pressed onto the neck by hand with the aluminum side towards the neck and the black insulation towards the nozzle.
3. Reinstall front-end consumables.

7-2 Changing the Neck



1. Remove front-end consumables (see section 7-1 Changing Consumables on page 16).
2. Using a 5 mm Allen wrench, loosen screw 1/4 turn to remove the neck.
3. Pull neck directly out of the connector housing.
4. Insert replacement neck into the connector housing, ensuring the key on the neck is lined up with the keyway on the gun.
5. Tighten screw to 60 in-lbs (7 Nm) using a 5 mm Allen wrench.
6. Reinstall consumables.

Figure 7-B

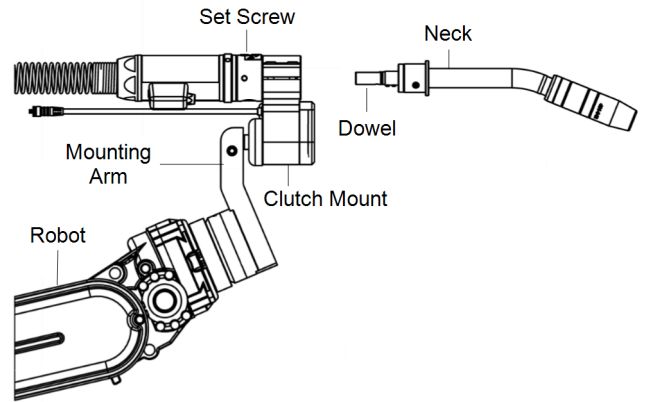

7-3 Changing TOUGH GUN I.C.E.™ Components

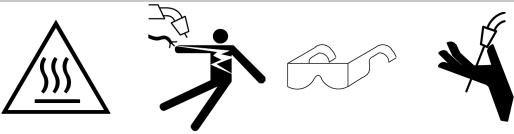

1. Remove front-end consumables (see section 7-1 Changing Consumables on page 16).
2. Remove screw and remove water line bracket.
3. Disconnect both water lines at quick connect couplers.

Figure 7-C

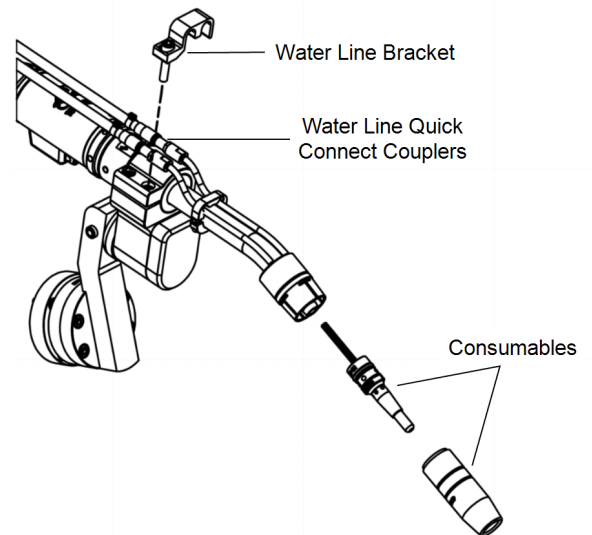

4. Loosen neck bolt (7-2 Changing the Neck on page 17).
5. Remove TOUGH GUN I.C.E. components / neck assembly.
NOTE: If existing clamping device on arm has 2 bolts, remove only the front bolt and snug the rear bolt.

Figure 7-D

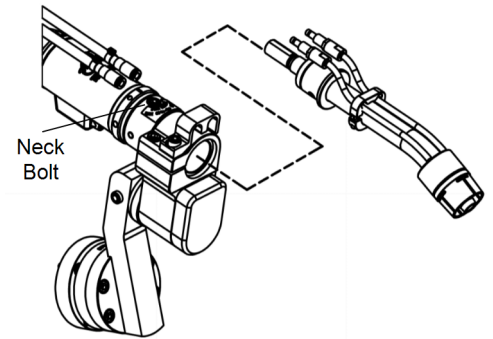

6. Reinstall TOUGH GUN I.C.E. components / neck assembly.
7. Tighten neck bolt to torque specification of 60 in-lbs (7 Nm).

Figure 7-E

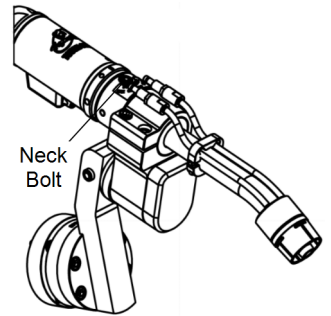

8. Connect water lines with quick connect couplers.
9. Fasten water line bracket with bolt (bracket and bolt included with TOUGH GUN I.C.E. assembly).
NOTE: Ensure both bolts are tightened on the mounting clamp.
10. Reinstall front-end consumables.

Figure 7-F

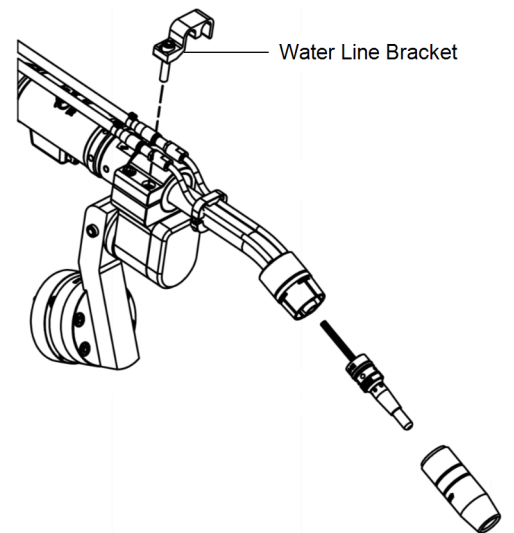

7-4 Changing the Liner

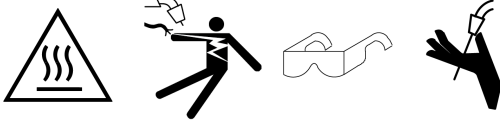

A. Changing QUICK LOAD® Liner

NOTE: Ensure power supply is off before proceeding.

1. Remove consumables (nozzle, contact tip and retaining head / diffuser) (see section 7-1 Changing Consumables on page 16).
2. Remove existing QUICK LOAD Liner by pulling it out from the neck.
3. Insert the new QUICK LOAD Liner through the neck using the welding wire as a guide (short strokes will prevent kinking).
4. Once liner stops feeding, give it an extra push until it bottoms out in the liner retainer in the power pin to ensure it is inserted completely.
5. Push liner back into gun and hold in place. Using liner gauge, trim liner to a 1/2" stick-out for gun lengths 6 feet and shorter, or 3/4" stick-out for gun lengths longer than 6 feet. **HELPFUL HINT:** Before cutting the liner with wire inside, mark the liner using the gauge and then pull the liner out beyond the end of the welding wire; then cut the liner and push it back into place securely. This will help with feeding the wire through the contact tip afterward.
6. Remove any burr that may obstruct wire feed.
7. Reinstall consumables onto neck.

Figure 7-G

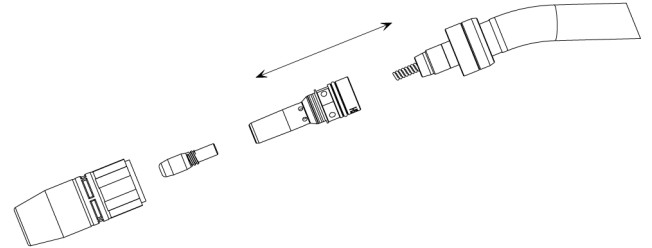

Figure 7-H

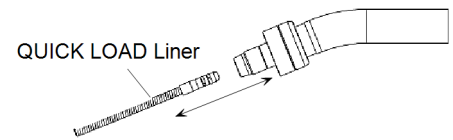
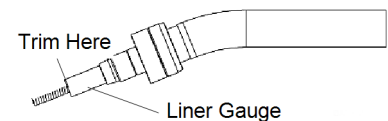

Figure 7-I



B. Changing QUICK LOAD Liner in the AutoLength System

NOTE: Ensure power supply is off before proceeding.

1. Remove consumables (nozzle, contact tip and retaining head / diffuser) (see section 7-1 Changing Consumables on page 16).
2. Remove existing QUICK LOAD Liner by pulling it out from the neck.
3. Insert the new QUICK LOAD Liner through the neck using the welding wire as a guide (short strokes will prevent kinking).
4. Feed liner into the gun until it engages with the retainer inside the AutoLength Pin. Place the liner gauge onto the end of the QUICK LOAD Liner and press flush with the end of the neck.
5. Push the QUICK LOAD Liner into the gun until the liner will not go forward any further. **NOTE:** Liner will be pushed in by approximately one additional inch.
6. Using the liner gauge, trim the liner with a 1/2" stick-out for gun lengths 6 feet and shorter, or a 3/4" stick out for gun lengths longer than 6 feet. **NOTE:** After trimming, the liner will stick out of the neck by approximately 1-3/4". This is normal, as the liner will be pushed back into the neck when the consumables are installed.
7. Feed wire through the MIG gun.
8. Reinstall consumables.

7-5 Changing the Power Pin or AutoLength™ Pin



IMPORTANT: The thread-in two-piece power pin incorporates a taper to seat and lock the power pin into the rear handle block. Make sure power pin is tightened in the block with a wrench to ensure pin is secure and will not come loose.

NOTE: The rear handle and screws do not have to be removed when installing the two-piece power pins.

1. Thread power pin into rear handle block.
2. Tighten the power pin into the rear block using a wrench on the rear block and a wrench on the power pin.
3. Install liner (see section 7-4 Changing the Liner on page 19).
4. Install gun to feeder (see below):

Figure 7-J

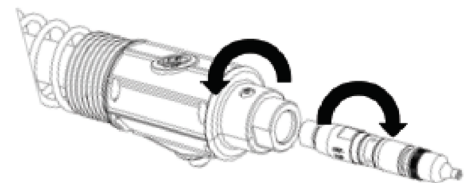

Miller® Power Pin and Lincoln® Power Pin

- Insert power pin to shoulder and secure.
- Insert control plug to control housing of gun.
- Insert control plug into feeder.
- Feed welding wire into power pin by hand and tighten drive rolls.
- On Lincoln, it is necessary to connect gas hose to gas fitting on power pin.

Bernard® Style and Euro-Connector

- Feed welding wire through female adaptor by hand and tighten drive rolls.
- Guide welding wire into connector on the gun, carefully insert connector into female adaptor and tighten Euro hand nut or Bernard style locking collar.

ESAB® Power Pin (Non-Euro Style)

- Insert power pin into shoulder and secure.
- Feed welding wire into power pin by hand and tighten.

7-6 Changing the Replaceable Unicable



1. Remove nozzle, retaining head / diffuser and liner.
2. **FOR CLUTCH MODELS ONLY:** Disconnect external clutch cable from the clutch connector housing.
3. Loosen cable guide.

Figure 7-K

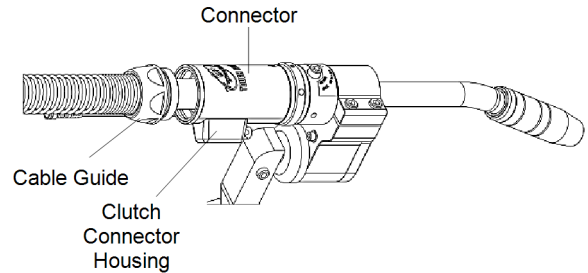

4. **FOR CLUTCH MODELS ONLY:** Remove clutch connector housing and disconnect internal wiring (see Figure 7-L).
5. Turn connector counterclockwise to “UNLOCK” position (indicated by an “UNLOCK” position icon on the sticker) and slide away from the front housing to expose cable lock screw.

Figure 7-L

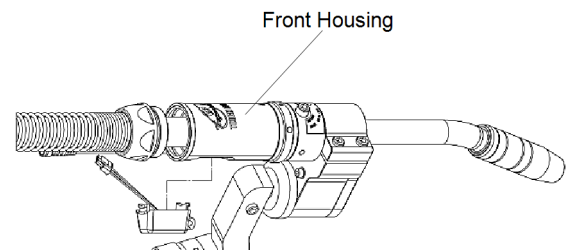

6. Unlock power connection between the cable and front housing using a 5 mm Allen wrench (see Figure 7-M).

Figure 7-M

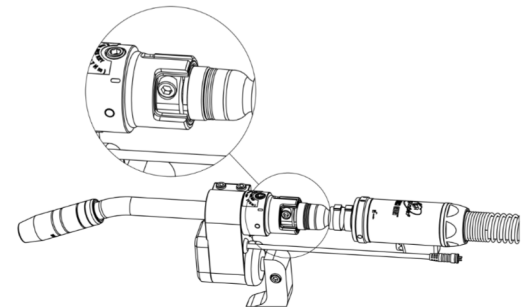

7. Release cable assembly by turning a 1/4 turn counterclockwise (see Figure 7-N).
8. Remove uncable.
9. Remove connector from cable assembly. Connector should be kept for the replacement uncable.
10. Remove power pin from uncable.
11. Discard old uncable and liner. **NOTE:** You will need to install a new liner to avoid discrepancies between the new uncable length and the length of the liner.
12. Reinstall power pin onto new cable.
13. Slide the connector that was removed from the old uncable over the front housing of the new uncable assembly.

Figure 7-N

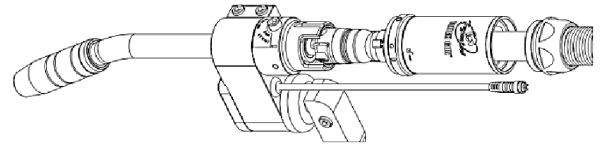

14. **FOR CLUTCH MODELS ONLY:** Connect internal clutch wiring and snap clutch connector housing into the connector.
15. **FOR CLUTCH MODELS ONLY:** Thread cable guide onto connector while holding the clutch connector housing in place. There is an undercut on the connector that allows the cable guide to hold this housing in place when installed properly.
16. Slide the uncable assembly onto the connector stud (on the back of the connector) and turn a 1/4 turn clockwise. Fasten the 5 mm SHCS to lock the uncable into place.
17. Slide the connector into place and turn a 1/4 turn clockwise to lock it into place.
18. **FOR CLUTCH MODELS ONLY:** Reconnect the external clutch cable.

Figure 7-O

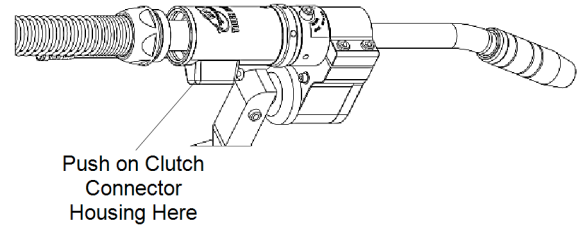

7-7 Replacing the Wire Brake



1. Remove power pin from feeder.
2. Trim and remove excess wire.
3. Remove front-end consumables and neck, including jump liner.
4. Shut off and disconnect 1/8" air supply at the wire brake pushing unit (see Figure 7-P).
5. Loosen two bolts and pull the gun assembly (see Figure 7-Q).

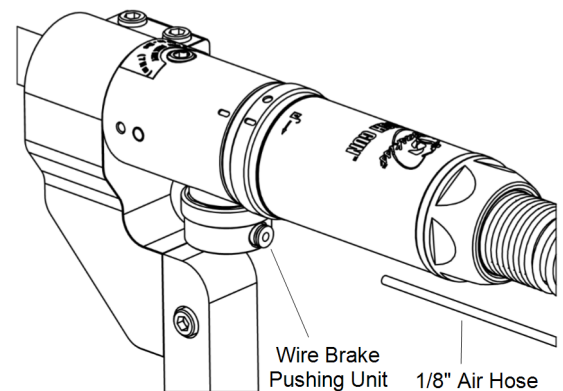

Figure 7-P

6. Unthread and remove the wire brake pushing unit to allow the wire guide to be released (see Figure 7-R).

7. Carefully slide the wire guide using the wire guide tool out of the gun body (see Figure 7-S).

8. Inspect for wear and swap for proper wire size as required.

NOTE: 0.035"-0.045" with one guide, 0.052"-1/16" with another.

9. Reinstall appropriate wire guide using the wire guide tool with the flats oriented (see Figure 7-S). Align the hole with the pushing unit pin (see Figure 7-R). Thread in the pushing unit.

10. Reinstall power pin to feeder.

11. Reinstall consumables and neck, including the jump liner.

12. Feed wire through the gun.

12. Reconnect the air lines and turn on the air pressure.

13. Disconnect drive rolls to allow wire to be pulled through the gun. Pull 6'-8' out of the gun. **NOTE:** The wire should pull through the gun easily. If the wire binds, double check the wire guide to ensure it's the proper size. Trim to proper stick out.

14. Activate wire brake via robot controller and attempt to pull additional wire out from gun. **NOTE:** The wire should no longer move.

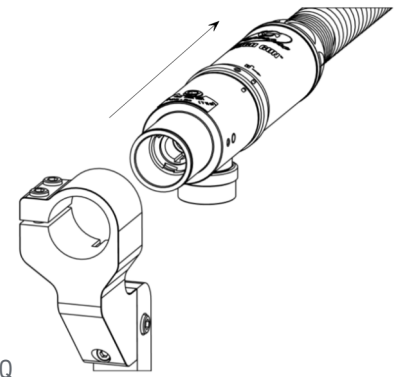

Figure 7-Q

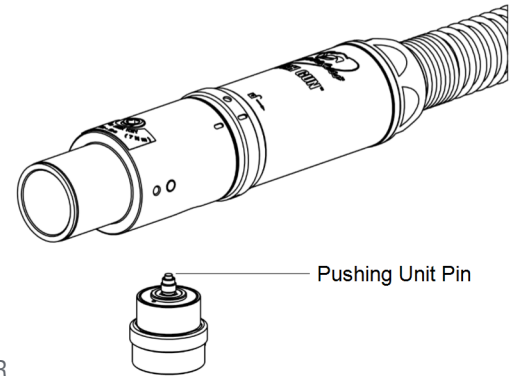

Figure 7-R

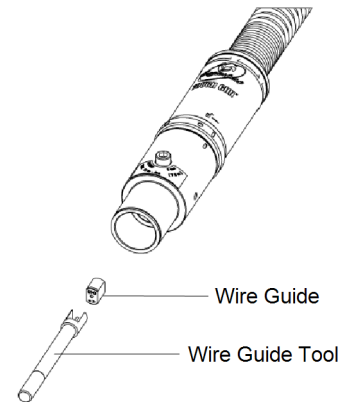
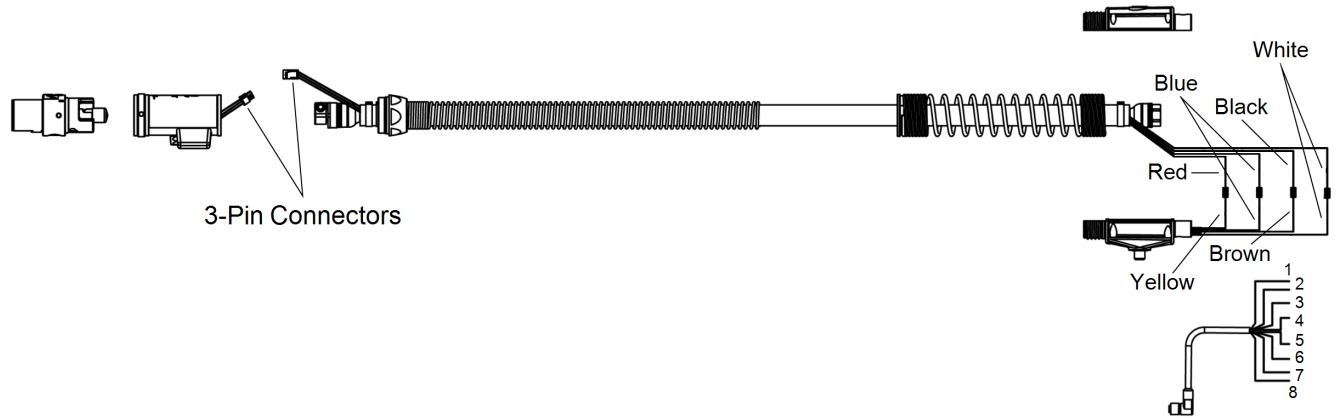

Figure 7-S

SECTION 8 — TECHNICAL DATA

8-1 Wiring Diagram



- 1. White - Clutch
- 2. Brown - Clutch
- 3. Yellow (Voltage Sense)
- 4. Blue (Not Used)

- 5. Green (Not Used)
- 6. Red (Not Used)
- 7. Pink (Not Used)
- 8. Gray (Not Used)

*For legacy installations with AS-708 clutch, use the following:

- 1. White +24DC supply
- 2. Brown +24DC output
- 4. Blue 0 VDC

8-2 Center of Mass Coordinates

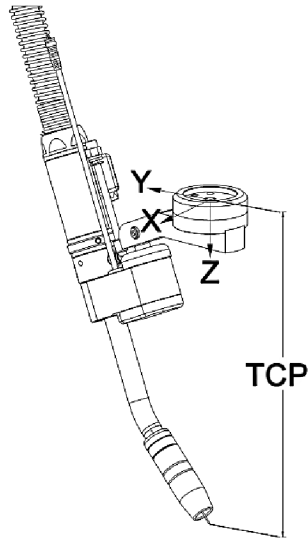

Standard Configurations - Clutch Mount				
22 Degree	X	Y	Z	Weight
316 mm TCP (405-22QC + CA2201)	-0.50 mm	150.30 mm	6.47 mm	2.98 kg
350 mm TCP (405-22QCL + CA2202)	-0.46 mm	165.80 mm	-0.26 mm	3.09 kg
400 mm TCP (405-22QCL + CA2203)	-0.48 mm	165.34 mm	44.19 mm	3.11 kg
45 Degree	X	Y	Z	Weight
350 mm TCP (405-45QCL + CA4501)	-0.50 mm	91.35 mm	5.73 mm	3.01 kg
400 mm TCP (405-45QCL1 + CA4502)	-0.49 mm	92.12 mm	11.54 mm	3.07 kg
180 Degree	X	Y	Z	Weight
294 mm TCP (405-180QC + CA1801)	-0.49 mm	206.24 mm	40.08 mm	3.04 kg

Standard Configurations - Solid Mount				
22 Degree	X	Y	Z	Weight
316 mm TCP (405-22QC + CA2201)	-0.49 mm	156.75 mm	-1.62 mm	2.71 kg
350 mm TCP (405-22QCL + CA2202)	-0.47 mm	171.31 mm	-6.87 mm	2.82 kg
400 mm TCP (405-22QCL + CA2203)	-0.46 mm	170.78 mm	37.07 mm	2.83 kg
45 Degree	X	Y	Z	Weight
350 mm TCP (405-45QCL + CA4501)	-0.48 mm	94.14 mm	-4.24 mm	2.74 kg
400 mm TCP (405-45QCL1 + CA4502)	-0.51 mm	94.94 mm	2.84 mm	2.79 kg
180 Degree	X	Y	Z	Weight
294 mm TCP (405-180QC + CA1801)	-0.48 mm	214.37 mm	35.19 mm	2.76 kg

SECTION 9 — PARTS LIST

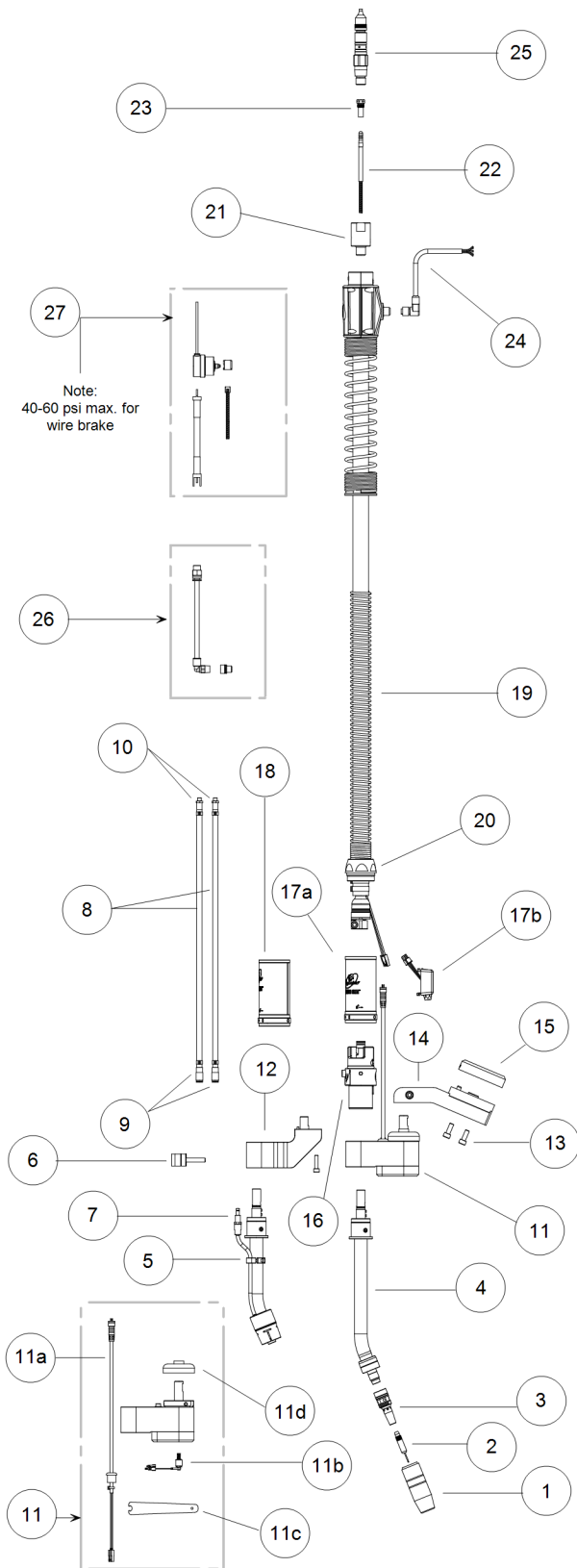

ITEM	PART #	DESCRIPTION
1	See SP-CA3	Nozzle
2	See SP-CA3	Contact Tip
3	See SP-CA3	Retaining Head / Diffuser
4	405-22QC	Neck, 22 degree, short length
	405-22QCL	Neck, 22 degree, medium length
	405-45QC	Neck, 45 degree, short length
	405-45QCL	Neck, 45 degree, medium length
	405-45QCL1	Neck, 45 degree, long length
	405-180QC	Neck, 180 degree, medium length
5	See SP-CA3	Neck, TOUGH GUN I.C.E.™ assembly
6	590-9	Water Line Bracket (TOUGH GUN I.C.E. assembly component)
7	590-8	Water Line Fittings, Male
8	590-4	TOUGH GUN I.C.E. water lines, 15-ft (includes ITEM 9 and ITEM 10)
	590-5	TOUGH GUN I.C.E. water lines, 20-ft (includes ITEM 9 and ITEM 10)
9	810-10-5	Water Line Fittings, Female + clamps
10	658-2	Quick Connect Brass Fittings, Male + clamps (included in ITEM 9)
11	CACM	Clutch Mount
11a	CACM21	Power Cord, Clutch Mount
11b	AS-715-9	Switch Assembly, Clutch Mount
11c	AS-715-17	Adjusting Sleeve Wrench, Clutch Mount
11d	AS-715-11	Dust Boot, Clutch Mount
12	CASM	Solid Mount
13	Not Sellable	16 mm M6 SHCS
14	CA2201	Mounting Arm for 22 degree short length neck
	CA2202	Mounting Arm for 22 degree medium length neck
	CA2203	Mounting Arm for 22 degree medium length neck
	CA4501	Mounting Arm for 45 degree medium length neck
	CA4502	Mounting Arm for 45 degree long length neck
	CA1801	Mounting Arm for 180 degree medium length neck
15	See SP-CA3	Insulating Disc
16	508-400	Connector Housing
	508-400W	Connector Housing (for guns equipped w/wire brake)
17a	610-400A	Cable Connector Cover, Clutch Mount
17b	610-400-8	Clutch Connector Housing
18	610-400B	Cable Connector Cover, Solid Mount
19	See SP-CA3	Replaceable Unicable
20	Not Sellable	Cable Guide (included with ITEM 19)
21	414-600	Adaptor (included with ITEM 19)
22	See SP-CA3	QUICK LOAD™ Liner Conventional Liner (for guns equipped with wire brake)
23	415-26	QUICK LOAD Liner Retainer
24	See SP-CA3	Control Cable
25	See SP-CA3	Power Pin
26	508-A	Air Blast Kit Option
27	WB-599-045*	Wire Brake Kit for 0.045" wire
	WB-599-116*	Wire Brake Kit for 1/16" wire

*508-400W (see 16 above) required if retrofitting wire brake

SECTION 10 — TROUBLESHOOTING

10-1 Troubleshooting Table

PROBLEM	POSSIBLE CAUSE	CORRECTIVE ACTION
1. Electrode does not feed.	<ol style="list-style-type: none"> 1. Feeder relay. 2. Broken control lead. 3. Poor adaptor connection. 4. Improper / worn drive roll. 5. Drive roll tension misadjusted. 6. Burn back to contact tip. 7. Wrong size liner. 8. Buildup inside of liner. 	<ol style="list-style-type: none"> 1. Consult feeder manufacturer. 2. a. Test and connect spare control lead. b. Install new cable. 3. Test and replace leads and/or contact pins. 4. Replace drive roll. 5. Adjust tension at feeder. 6. See 'Contact tip burn back'. 7. Replace with correct size. 8. Replace liner or clean out with compressed air, check condition of electrode.
2. Contact tip burn back.	<ol style="list-style-type: none"> 1. Improper voltage and/or wire feed speed. 2. Erratic wire feeding. 3. Improper tip stickout. 4. Improper electrode stickout. 5. Faulty ground. 	<ol style="list-style-type: none"> 1. Adjust parameters. 2. See 'Erratic wire feeding'. 3. Adjust nozzle / tip relationship. 4. Adjust wire stickout. 5. Replace cables and/or connections.
3. Tip disengages from the gas diffuser.	<ol style="list-style-type: none"> 1. Worn retaining head / diffuser. 2. Improper tip installation. 3. Extreme heat or duty cycle. 	<ol style="list-style-type: none"> 1. Replace tip and/or gas diffuser / retaining head / diffuser. 2. Install as per section 7-1 Changing Consumables on page 16. 3. Replace with heavy duty consumables. See appropriate Spec Sheet for details.
4. Short contact tip life.	<ol style="list-style-type: none"> 1. Contact tip size 2. Electrode eroding contact tip. 3. Exceeding duty cycle. 	<ol style="list-style-type: none"> 1. Replace with proper size. 2. Inspect and/or change drive rolls. 3. Replace with properly rated Tregaskiss MIG Gun.
5. Erratic arc.	<ol style="list-style-type: none"> 1. Worn contact tip. 2. Buildup inside of liner. 3. Wrong tip size. 4. Not enough bend in neck. 	<ol style="list-style-type: none"> 1. Replace contact tip. 2. Replace liner, check condition of electrode. 3. Replace with correct tip size. 4. Replace with 45° neck.
6. Erratic wire feeding.	<ol style="list-style-type: none"> 1. Buildup inside of liner. 2. Wrong size liner. 3. Improper drive roll size. 4. Worn drive roll. 5. Improper guide tube relationship. 6. Improper wire guide diameter. 7. Gaps at liner junctions. 8. Feeder malfunction. 9. Worn contact tip. 	<ol style="list-style-type: none"> 1. Replace liner, check condition of electrode. 2. Replace with new liner of proper size. 3. Replace with proper size drive roll. 4. a. Replace with new drive roll. b. Repair worn drive roll. 5. a. Adjust / replace guide as close to drive rolls as possible. b. Eliminate all gaps in electrode path. 6. Replace with proper guide diameter. 7. a. Replace with new liner trimmed as per section 7-4 Changing the Liner on page 19. b. Replace guide tube / liner trimming as close to mating component as possible. 8. Consult feeder manufacturer. 9. Inspect and replace.*
7. Extreme spatter.	<ol style="list-style-type: none"> 1. Improper machine parameters. 2. Improper tip installation. 3. Improper shielding gas coverage. 4. Contaminated wire or workpiece. 	<ol style="list-style-type: none"> 1. Adjust parameters. 2. Adjust nozzle / tip relationship. 3. a. Verify shielding gas coverage. b. Verify gas mixture. 4. Clean wire and workpiece.

8. Porosity in weld.	<ol style="list-style-type: none"> 1. Insulator worn. 2. Gas diffuser damaged 3. Extreme heat or duty cycle. 4. Solenoid faulty. 5. No gas. 6. Flow improperly set. 7. Gas ports plugged. 8. Ruptured gas hose. 9. Control circuit loss. 10. Worn, cut or missing o-rings. 11. Loose fittings. 	<ol style="list-style-type: none"> 1. Replace nozzle / insulator. 2. Replace gas diffuser or o-rings. 3. Replace with heavy duty consumables. 4. Replace solenoid. 5. <ol style="list-style-type: none"> a. Install full tanks. b. Check supply. c. Check for hose leaks. 6. Adjust flow. 7. <ol style="list-style-type: none"> a. Clean or replace gas diffuser. b. Clean nozzle. 8. Repair or replace cable or line. 9. See 'Electrode does not feed'. 10. Replace o-rings. 11. Tighten gun and cable connections to specified torque. See Section 7 — Replacement on page 16.
9. Gun running hot.	<ol style="list-style-type: none"> 1. Exceeding duty cycle. 2. Loose or poor power connection. 	<ol style="list-style-type: none"> 1. <ol style="list-style-type: none"> a. Replace with properly rated Tregaskiss MIG Gun. b. Decrease parameters to within gun rating. 2. <ol style="list-style-type: none"> a. Clean, tighten or replace cable grounding connection. b. Tighten gun and cable connections to specified torque. See Section 7 — Replacement on page 16.
10. Liner is discolored.	<ol style="list-style-type: none"> 1. Short circuit to electrode. 2. Broken copper stranding in power cable. 	<ol style="list-style-type: none"> 1. Isolate electrode reel from feeder and drive block. Consult feeder manufacturer's manual. 2. Replace unicable.
11. Sporadic feeding of aluminum electrode.	<ol style="list-style-type: none"> 1. Tip galling. 2. Synthetic liner melting. 3. Wire deformed by feeder rolls. 	<ol style="list-style-type: none"> 1. Inspect and replace the contact tip.* 2. <ol style="list-style-type: none"> a. Replace liner. b. Replace with composite liner. c. Replace the neck and jump liner. 3. Adjust drive rolls as per feeder manufacturer's manual.

**In some cases with aluminum and mild steels, it may be necessary to use a contact tip with either a larger or smaller bore size.*

ADDITIONAL SUPPORT MATERIALS

For additional support materials such as Spec Sheets, troubleshooting information, how-to guides and videos, animations, online configurators and much more, please visit Tregaskiss. Scan the QR Code with your smart phone for immediate access to bernardtregaskiss.com/TechnicalSupport.



Scan to view the TOUGH GUN® CA3 MIG Gun Owner's Manual



Scan to view the TOUGH GUN® CA3 MIG Gun Spec Sheet



Scan to view the AccuLock™ R (Robotic) Consumables Spec Sheet



Scan to view the TOUGH LOCK® Consumables Spec Sheet



Scan to view the QUICK LOAD® Liners & AutoLength™ Pins Spec Sheet



Scan to view Tregaskiss® Owner's Manuals and Spec Sheets



Tregaskiss
2570 North Talbot Road
Windsor, Ontario NOR 1L0
Canada

Phone: 1-855-MIGWELD (644-9353) (US & Canada)
+1-519-737-3000 (International)
Fax: 1-519-737-1530



For more information, visit us at bernardtregaskiss.com
