

Tregaskiss® BA1

Cobot Air-Cooled MIG Gun

Issued June 2024 • Index No. BA1/1.9

MIG (GMAW) 
Robotic Welding

Quick Specs

Duty Cycle Rating

100%: 350 amp with Mixed Gases

Ratings are based on tests that comply with IEC 60974-7 standards

Processes

MIG (GMAW) Welding

Cobots

Universal Robots (UR)
 FANUC®
 Yaskawa Motoman

Welding Machines

Compatible with most brands of welding machines.
 (see Power Pin Options p.7)

Cobot users expect a quick-to-implement and easy-to-use automation solution that keeps their operations agile and profitable. Tregaskiss® BA1 cobot air-cooled MIG guns deliver this through their proven durability and overall simplicity of design – keeping weld operators focused on manufacturing quality parts instead of troubleshooting or maintaining MIG guns.

AccuLock™

AccuLock™ MIG gun consumables were designed to maximize production uptime through their long service life and quick and accurate replacement.

To further reduce the potential for error through simplified inventory, AccuLock consumables share a common contact tip across Bernard® semi-automatic, and Tregaskiss robotic, fixed automatic and cobot MIG welding guns.

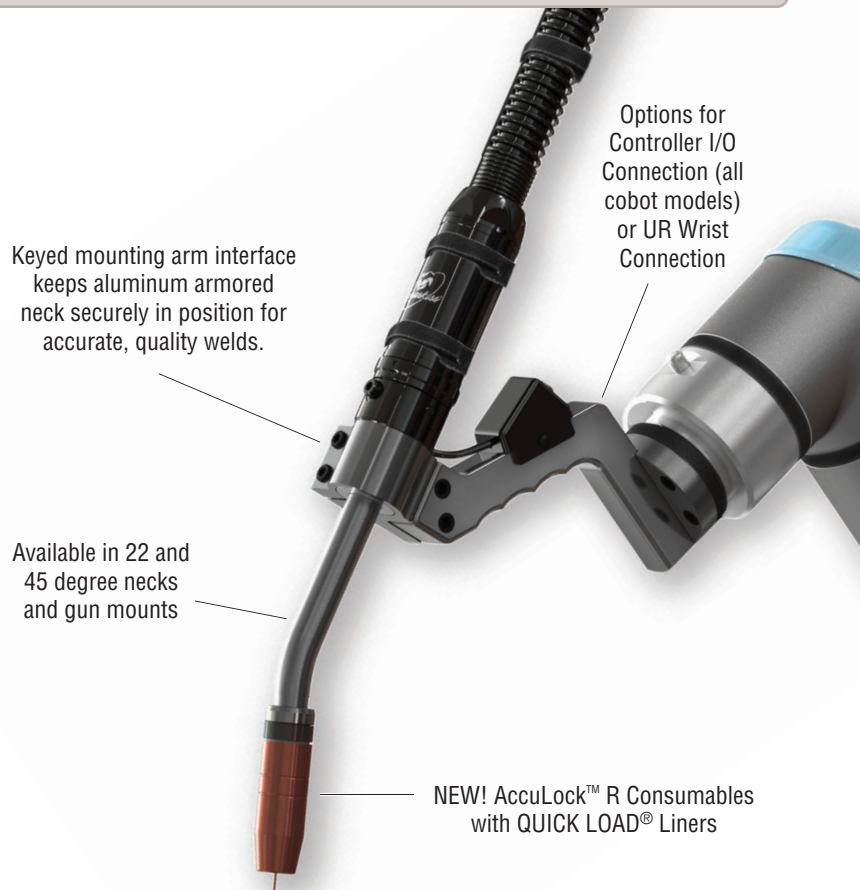

Tregaskiss
 2570 North Talbot Road
 Windsor, Ontario N0R 1L0
 Canada

Phone: 1-855-MIGWELD (644-9353) (US & Canada)
 +1-519-737-3000 (International)
 Fax: 519-737-1530
 For more information, visit us at Tregaskiss.com

System Components

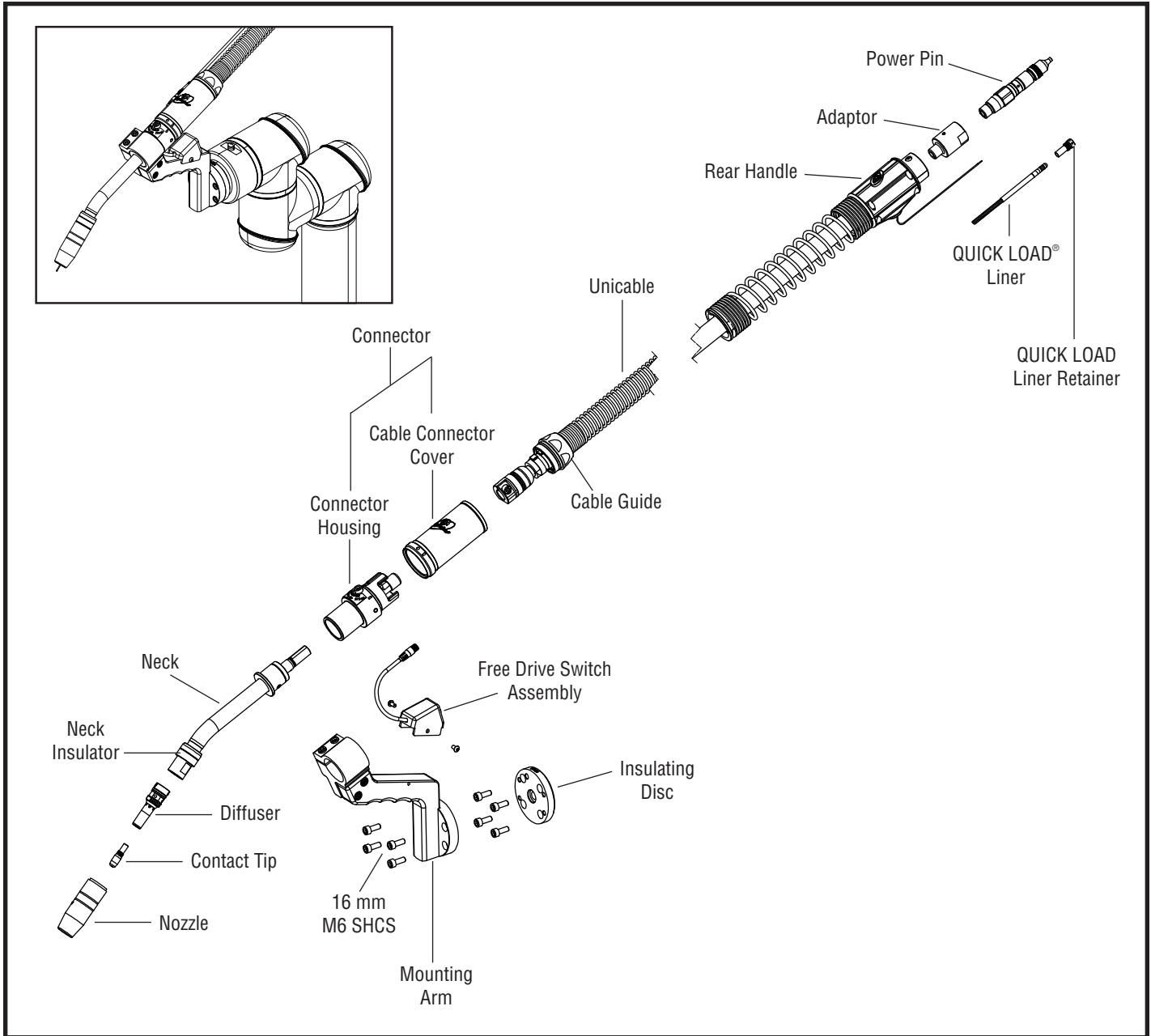

Know Your Options



AccuLock™ R Consumables

Eliminate contact tip cross-threading issues with new AccuLock R Consumables. These new consumables are designed for increased tip life, which can reduce replacement frequency and related downtime. AccuLock HDP Contact Tips can increase life by an additional 6-10x longer in pulse welding applications. And in most cases, your current tip and diffuser can be replaced with no impact to Tool Center Point (TCP), making this upgrade low effort, low risk, and high payoff.



QUICK LOAD® Liners

The QUICK LOAD Liner System loads from the front of the MIG gun, and requires less than half the time and effort for replacement when compared with conventional liners. These liners interface with a QUICK LOAD Liner Retainer that is seated within the power pin of the gun on first use. QUICK LOAD Liners come standard on Tregaskiss® cobot MIG Guns. Available for wire sizes between 0.030" and 3/32" and in lengths of up to 15 feet.

Gun Configurations

NOTE: For Center Of Mass information, see owner's manual OM-BA1 at Tregaskiss.com/BA1

Configuration – 22 Degree Neck

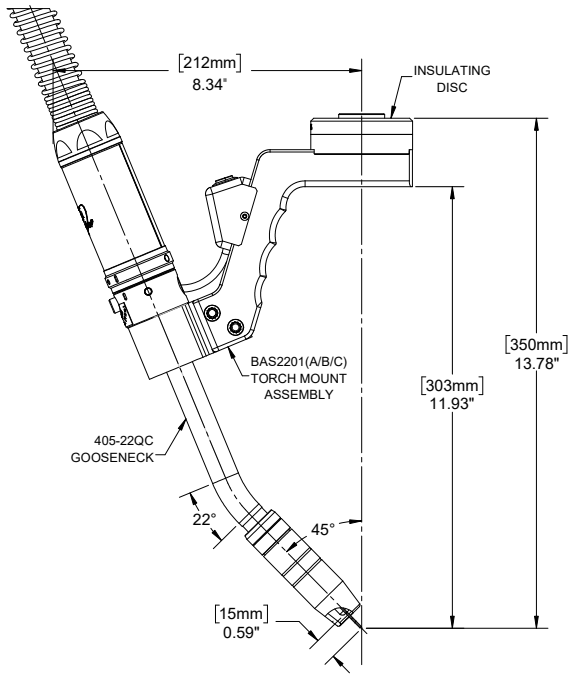

350 mm (13.78") TCP,
Neck 405-22QC

Configuration – 45 Degree Neck

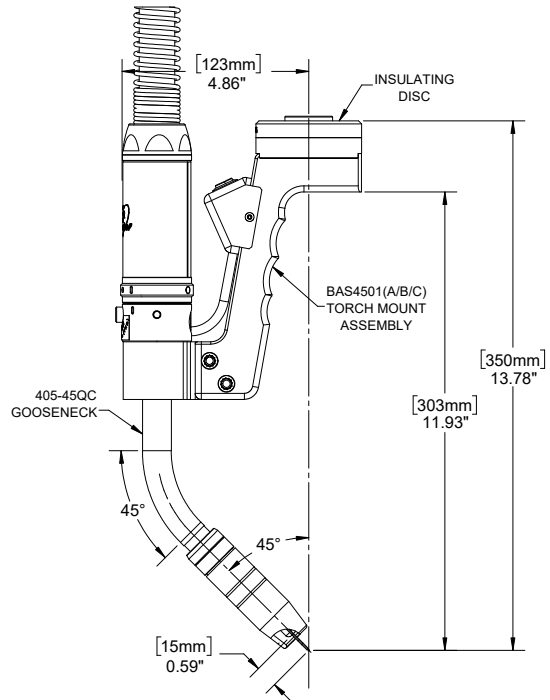

350 mm (13.78") TCP,
Neck 405-45QC

Consumable Options

AccuLock™ Heavy Duty (HD) Copper Contact Tips

T-A030CH*	for 0.030" (0.8 mm) wire; qty. 10	T-A062CH	for 1/16" (1.6 mm) wire; qty. 10
T-A035CH*	for 0.035" (0.9 mm) wire; qty. 10	T-A072CH	for 0.070" (1.8 mm) wire; qty. 10
T-A039CH*	for 0.039" (1.0 mm) wire; qty. 10	T-A078CH	for 5/64" (2.0 mm) wire; qty. 10
T-A045CH*	for 0.045" (1.2 mm) wire; qty. 10	T-A094CH	for 3/32" (2.4 mm) wire; qty. 10
T-A052CH*	for 0.052" (1.3 mm) wire; qty. 10		

NOTE: add "-100" to the end of the above HD copper contact tip part numbers for quantities of 100.
 *add "-1000" to the end of the above part numbers for quantities of 1000.

AccuLock Heavy Duty (HD) Chrome Zirconium Contact Tips

T-A030ZH	for 0.030" (0.8 mm) wire; qty. 10	T-A045ZH	for 0.045" (1.2 mm) wire; qty. 10
T-A035ZH	for 0.035" (0.9 mm) wire; qty. 10	T-A052ZH	for 0.052" (1.3 mm) wire; qty. 10
T-A039ZH	for 0.039" (1.0 mm) wire; qty. 10	T-A062ZH	for 1/16" (1.6 mm) wire; qty. 10

NOTE: add "-100" to the end of the above HD Chrome Zirconium contact tip part numbers for quantities of 100.

AccuLock HDP Contact Tips

T-A035WH	for 0.035" (0.9 mm) wire; qty. 10	T-A045WH	for 0.045" (1.2 mm) wire; qty. 10
T-A039WH	for 0.039" (1.0 mm) wire; qty. 10	T-A052WH	for 0.052" (1.3 mm) wire; qty. 10

NOTE: add "-100" to the end of any of the above HDP contact tip part numbers for quantities of 100.

AccuLock Teach Pointers (used for cobot programming)

T-A001TP	Adjustable teach pointer	T-A075TP	Teach pointer, 3/4" CTWD
T-A050TP	Teach pointer, 1/2" CTWD	T-A10MTP	Teach pointer, 10 mm CTWD
T-A062TP	Teach pointer, 5/8" CTWD	T-A15MTP	Teach pointer, 15 mm CTWD

AccuLock R Gas Diffusers

D-ATTH	Gas diffuser, thread-on, AccuLock R	D-ATSH	Gas diffuser, slip-on, AccuLock R
---------------	-------------------------------------	---------------	-----------------------------------

NOTE: add "-100" to the end of the above gas diffuser part numbers for quantities of 100.

Tregaskiss® Nozzles

Part Number	Description	Style	Configurator Digit
401-14-62	HD - 5/8" bore, 1/8" recess (copper)	Thread-on	D
401-43-62	SD - 5/8" bore, 1/8" recess (copper)	Thread-on	G
401-18-62	SD - 5/8" bore, 1/8" stick out (copper)	Thread-on	E
401-20-62	HD - 5/8" bore, 1/8" stick out (copper)	Thread-on	L
401-30-62T	SD - 5/8" bore, 1/8" stick out (bottleneck, brass)	Thread-on	4
401-6-62	HD - 5/8" bore, 1/8" recess (copper)	Slip-on	A
401-8-62	SD - 5/8" bore, 1/8" stick out (copper)	Slip-on	G
401-48-62	HD - 5/8" bore, flush tip (bottleneck, copper)	Slip-on	K
401-81-62	HD - 5/8" bore, 1/8" stick out (copper)	Slip-on	D
401-71-62	HD - 5/8" bore, 1/8" recess (bottleneck, brass)	Slip-on	N
401-87-62	HD - 5/8" bore, 1/8" stick out (brass)	Slip-on	P
401-30-62	HD - 5/8" bore, 1/8" stick out (bottleneck, brass)	Slip-on	3



TOUGH GARD® Anti-Spatter Liquid

This ready-to-use water-soluble, non-toxic product creates a sacrificial surface that reduces spatter adhesion. This prolongs the life of your consumables and minimizes downtime due to nozzle cleaning which can help reduce your operating and maintenance costs.

TG-101-32SP 32 fl. oz. / 946 mL (spray bottle)

For further information visit Tregaskiss.com/TOUGHGARD

Consumable Options *(Continued)*

QUICK LOAD® Liners

415-26	Liner retainer
415-24	Liner retainer (required for 3/32" wire)
415-30-6Q	for 0.030" (0.8 mm) wire; 6' (1.8 m)
415-30-15Q	for 0.030" (0.8 mm) wire; 15' (5.0 m)
415-35-6Q	for 0.035" (0.9 mm) - 0.045" (1.2 mm) wire; 6' (1.8 m)
415-35-10Q	for 0.035" (0.9 mm) - 0.045" (1.2 mm) wire; 10' (3.05 m)
415-35-15Q	for 0.035" (0.9 mm) - 0.045" (1.2 mm) wire; 15' (5.0 m)
415-116-6Q	for 0.052" (1.3 mm) - 1/16" (1.6 mm) wire; 6' (1.8 m)
415-116-10Q	for 0.052" (1.3 mm) - 1/16" (1.6 mm) wire; 10' (3.05 m)
415-116-15Q	for 0.052" (1.3 mm) - 1/16" (1.6 mm) wire; 15' (5.0 m)
415-564-6Q	for 1/16" (1.6 mm) - 5/64" (2.0 mm) wire; 6' (1.8 m)
415-564-15Q	for 1/16" (1.6 mm) - 5/64" (2.0 mm) wire; 15' (5.0 m)
415-332-6Q	for 0.078" (2.0 mm) - 3/32" (2.4 mm) wire; 6' (1.8 m) (requires 415-24 retainer)
415-332-15Q	for 0.078" (2.0 mm) - 3/32" (2.4 mm) wire; 15' (5.0 m) (requires 415-24 retainer)

QUICK LOAD E-Z Feed™ Liners — for cored and aluminum wire

415-31	Liner retainer
415-35-062Q	for 0.035" (0.9 mm) - 0.045" (1.2 mm) wire; 6' (1.8 m) (requires 415-26 retainer)
415-116-062Q	for 0.045" (1.2 mm) - 1/16" (1.6 mm) wire; 6' (1.8 m) (requires 415-31 retainer)

Polymer Liners — for aluminum wire (must be used with below jump liners)

415-45-01	for 0.035" (0.9 mm) - 0.045" (1.2 mm) wire; 6' (1.8 m)
415-45-02	for 0.035" (0.9 mm) - 0.045" (1.2 mm) wire; 10' (3.05 m)
415-45-03	for 0.035" (0.9 mm) - 0.045" (1.2 mm) wire; 15' (5.0 m)
415-116-21	for 0.045" (1.2 mm) - 1/16" (1.6 mm) wire; 6' (1.8 m)
415-116-22	for 0.045" (1.2 mm) - 1/16" (1.6 mm) wire; 10' (3.05 m)
415-116-23	for 0.045" (1.2 mm) - 1/16" (1.6 mm) wire; 15' (5.0 m)

Jump Liners — used with above polymer liners for aluminum wire

415-25	for 0.030" (0.8 mm) - 1/16" (1.6 mm) wire; 8'
415-25-13	for 0.030" (0.8 mm) - 1/16" (1.6 mm) wire; 13'

Neck Options

Air-Cooled Necks

405-22QC	22 degree neck
405-45QC	45 degree neck

Power Pins Options

Power Pins

425-20E	Euro	214-7	Lincoln®	214-30	Panasonic®
214-17	Fronius®	214-40	Lincoln (short)	214	Tweco® #4
425E	L-Tec® Euro	214-1	Miller®	214-12	Tweco #5
				214-18	Tweco #5 (external gas line)

Mounting Options *(Sold Separately)*

Mounting Arm Assembly

Option A

BAS2201A Mounting arm assembly for 22 degree neck, standard, TCP 350 mm, for all cobot models

BAS4501A Mounting arm assembly for 45 degree neck, standard, TCP 350 mm, for all cobot models

Option B

BAS2201B Mounting arm assembly for 22 degree neck, with free drive switch for controller I/O connection (3-pin, 5 meter cable, not terminated), TCP 350 mm, for all cobot models

BAS4501B Mounting arm assembly for 45 degree neck, with free drive switch for controller I/O connection (3-pin, 5 meter cable, not terminated), TCP 350 mm, for all cobot models

Option C

BAS2201C Mounting arm assembly for 22 degree neck, with free drive switch for UR wrist I/O connection (8-pin connector), TCP 350 mm, for Universal Robots (UR) only

BAS4501C Mounting arm assembly for 45 degree neck, with free drive switch for UR wrist I/O connection (8-pin connector), TCP 350 mm, for Universal Robots (UR) only

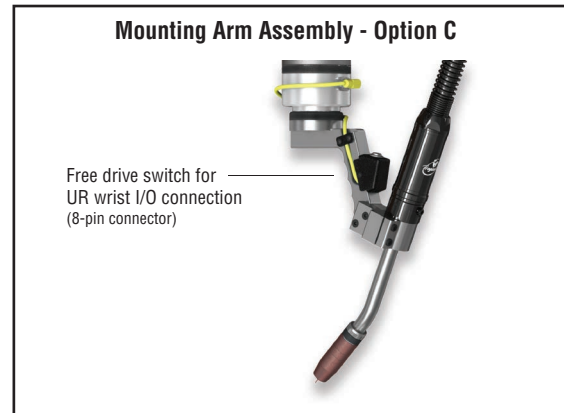

Insulating/Transition Discs

For Universal Robot (UR) cobots:

59D06 Insulating disc for Universal Robot cobot models: UR5, UR5e, UR10, UR10e, UR16, UR16e

For FANUC® cobots:

59D06 Insulating disc for Fanuc cobot models: CRX-5iA, CRX-10iA, CRX-10iA/L, CRX-20iA/L, CRX-25iA

59DT-010 Insulating disc for Fanuc cobot models: CR-4iA, CR-7iA, CR-7iA/L, CR-14iA/L, CR-15iA, CR-35iA
*kit includes transition disc and 59D01 insulating disc

For Yaskawa Motoman cobots:

59DT-013 Insulating disc for Yaskawa Motoman cobot models: HC10DT-XP
*kit includes transition disc and 59D02 insulating disc

Replacement Unicable *(Sold Separately)*

Unicables

BA1UXXS Replaceable unicable, solid mount

EBA1UXXS Replaceable unicable, solid mount (Euro)

NOTE: XX in the part numbers above represent cable length; i.e. BA1U04S = 4 ft, BA1U04.5S = 4.5 ft, BA1U10S = 10 ft, etc. (refer to Ordering Information on page 8 for available cable lengths)

Ordering Information

Step #1 - Tregaskiss BA1 Cobot MIG Guns

BA1 Series			Gun Style	Neck	Option #1	Contact Tip + Diffuser ⁺	Cable Length	Nozzle	Option #2	Wire Size	Power Pin
B	A	1	2	A	A	B	C	D	O	E	M
			2 Solid mount	Air-Cooled A 22 degree 405-22QC B 45 degree 405-45QC	A No options	AccuLock™ <i>For Slip-On Nozzles</i> A T-A0XXCH* + D-ATSH B T-A0XXZH** + D-ATSH C T-A0XXWH*** + D-ATSH <i>For Thread-On Nozzles</i> D T-A0XXCH* + D-ATTH E T-A0XXZH** + D-ATTH F T-A0XXWH*** + D-ATTH	A 3.0' B 3.5' C 4.0' D 4.5' E 5.0' F 5.5' G 6.0' J 7.0' L 8.0' N 9.0' R 10.0' S 12.0' T 15.0'	Slip-On A 401-6-62 D 401-81-62 G 401-8-62 K 401-48-62 N 401-71-62 P 401-87-62 3 401-30-62 Thread-On D 401-14-62 E 401-18-62 G 401-43-62 L 401-20-62 4 401-30-62T	0 No options	QUICK LOAD® <i>E-Z Feed™ Liner^</i> <i>for Cored Wire</i> A 0.035" N 1.0 mm P 0.045" W 0.052" Y 1/16" QUICK LOAD <i>Liner</i> B 0.030" C 0.035" D 1.0 mm E 0.045" G 0.052" J 1/16" K 0.070" L 0.078" M 3/32" <i>Polymer Liner</i> <i>for Aluminum Wire</i> R 0.035" T 1/16" U 0.045"	E Euro 425-20E F Fronius® 214-17 L Lincoln® 214-7 M Miller® 214-1 C L-Tec® Euro 425E P Panasonic® 214-30 R Tweco® #5 (external gas line) 214-18 S Lincoln (short) 214-40 T Tweco #4 214 W Tweco #5 214-12

+ Wire size = XX

* Not available for 0.078" wire size

** Available for 0.030", 0.035", 1.0 mm and 0.045" wire sizes

*** Available for 0.035", 1.0 mm, 0.045" and 0.052" wire sizes

^ QUICK LOAD Pro Liner features a special profile and coating for applications requiring extra wire feedability; Not available in cable lengths longer than 6 feet; For cored wire

Step #2 - Insulating/Transition Discs

Select your insulating disc from page 7 and enter it here:

Step #3 - Mounting Arms

Select your mounting arm from page 7 and enter it here:

Brand and product names shown above are trademarks of their respective owners.

Tregaskiss®, AccuLock™, TOUGH GUN®, TOUGH LOCK® and QUICK LOAD® are trademarks of Tregaskiss, a division of ITW Canada Inc.

Subject to Change – The information presented in this spec sheet is accurate to the best of our knowledge at the time of printing. Please visit Tregaskiss.com for the most up-to-date information.

Distributed By:

