

### How to Install the new TOUGH GUN CA3 MIG Gun Connector and Replaceable Unicable on the Legacy TOUGH GUN G1 Series Conventional Robotic MIG Gun

1. Remove nozzle, retaining head and liner (parts not shown).
2. Loosen the neck clamp SHCS using a 5 mm Allen wrench (see 'A' in *Figure 1*).
3. Remove the neck (see 'B' in *Figure 1*).

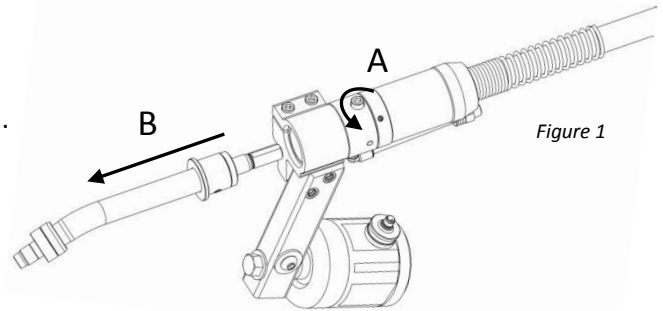

Figure 1

4. Loosen the 2x SHCS in the gun mount using a 5mm Allen wrench (see 'C' in *Figure 2*).
5. Remove the old TOUGH GUN G1 Series uncable (see 'D' in *Figure 2*).

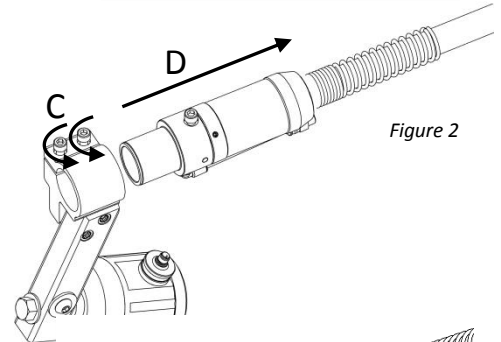

Figure 2

6. Line up the key of the new TOUGH GUN CA3 MIG Gun with the keyway in the gun mount and insert the new uncable connector and uncable into the gun mount as shown in *Figure 3*.

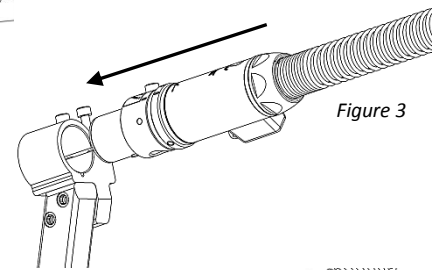

Figure 3

7. Tighten the 2x SHCS in the gun mount using a 5 mm Allen wrench (see *Figure 4*).

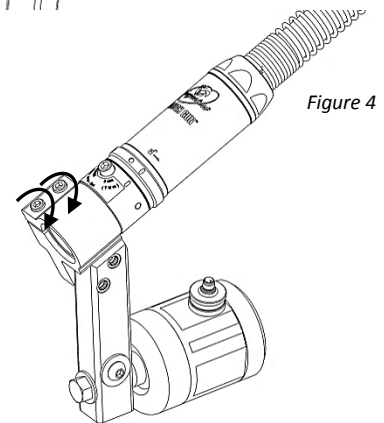

Figure 4

8. Line up the key of the neck with the keyway in the uncable connector and install as shown in 'E' of *Figure 5*.
9. Tighten the neck clamp SHCS using a 5 mm Allen Wrench (see 'F' in *Figure 5*).
10. Install and trim a new QUICK LOAD™ Liner, and reinstall the consumables.

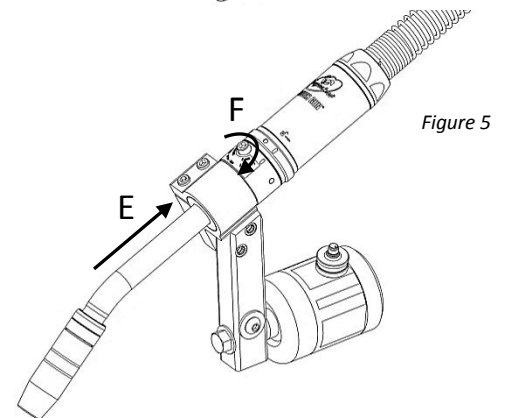

Figure 5